

Advanced AVB Integrator Application Guide

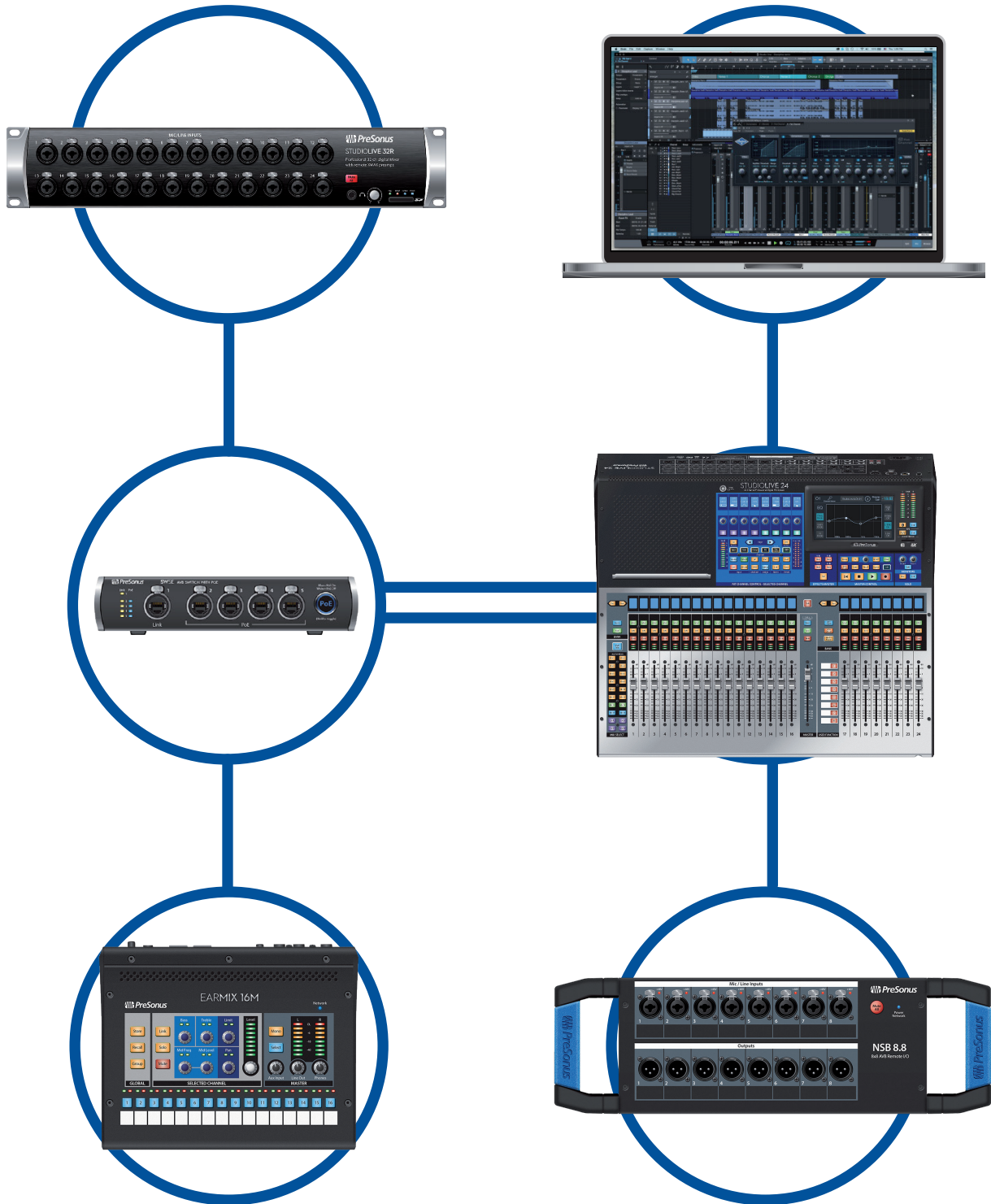

Table of Contents

1 Overview — 1

1.1 Introduction — 1

2 Installation Checklist — 2

2.1 Pre-Installation — 2

2.2 Networking Setup — 2

2.2.1 Control Network - Wired Ethernet — 2

2.2.2 Control Network - Wireless (WiFi) Ethernet — 2

2.2.3 Networking Setup - Audio Network — 3

2.3 Basic StudioLive Mixer Setup — 3

2.4 Basic NSB Setup — 3

2.5 Basic EarMix 16 Setup — 4

3 Firmware Update Instructions — 6

3.1 StudioLive Series III Console Mixers — 6

3.1.1 Update Using an SD Card — 6

3.1.2 Update from UC Surface (No Internet) — 7

3.1.3 Update Using UC Surface (Internet Access) — 9

3.2 StudioLive Series III Rack Mixers — 11

3.2.1 Update Using UC Surface Drag and Drop (No Internet Access) — 11

3.2.2 Update Using UC Surface (Internet Access) — 13

3.3 NSB Stage Boxes — 15

3.4 EarMix 16M Personal Monitor Mixers — 19

3.5 SW5E AVB Switch — 22

3.5.1 Additional Web Tool Interface Features — 25

4 Applications — 26

4.1 StudioLive Series III Console Mixer with NSB Stage Box — 26

4.2 StudioLive Series III Console with Rack Mixer — 30

4.2.1 Monitor Mixer Mode — 32

4.2.2 Stagebox Mode — 34

4.2.3 Editing Default AVB Inputs — 36

4.2.4 Preamp Control — 36

4.3 StudioLive Series III Consoles: FOH and Monitor Mixer Mode — 37

4.4 StudioLive Series III Console Mixer and EarMix 16M — 41

4.5 Putting It All Together: Real World Example — 43

5 Using AVB Streams from Multiple Sources — 50

5.1 AVB Input Stream Routing and Digital Patching — 50

6 Troubleshooting — 51

6.1 System Verification Checklist — 51

1 Overview

1.1 Introduction

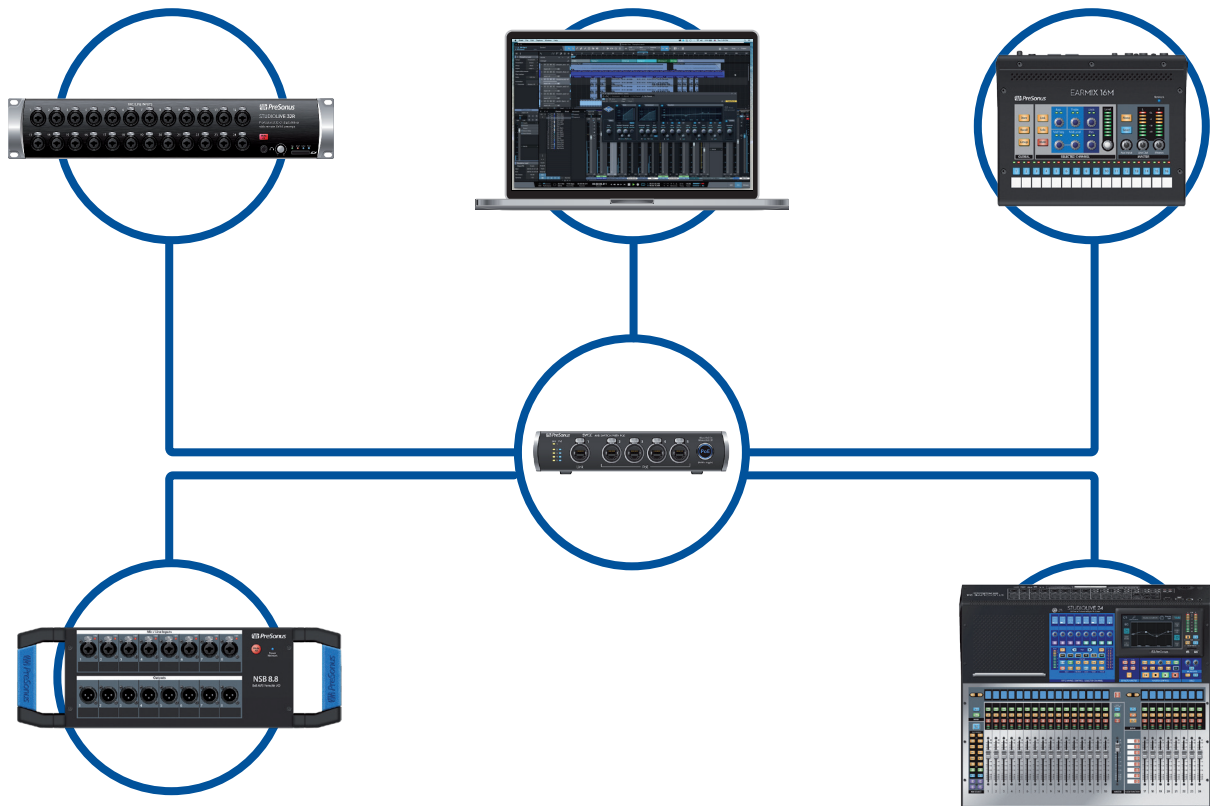

Welcome to the PreSonus Ecosystem! As a solutions company, we believe the best way to take care of our customers (that's you) is to ensure that you have the best possible experience from the beginning of your signal chain to the end. In order to achieve this goal, we've prioritized seamless integration throughout every design phase of the StudioLive Series III AVB ecosystem products from day one.

This Advanced AVB Networking Guide is designed to provide all the set-up information you need for your StudioLive products in a single location as well as to offer resources to help manage and troubleshoot large AVB networks.

Before you begin, here are some guidelines to help ensure the best networking experience possible:

2 Installation Checklist

Please print out and complete this checklist and save for your records.

2.1 Pre-Installation

- Register all StudioLive Series III Ecosystem products at My.PreSonus.com or using the My PreSonus app.
- My.PreSonus account username: _____
- Update all StudioLive Series III Ecosystem product firmware.
- See Section 3.1 for StudioLive Series III console mixer firmware update instructions.*
- See Section 3.2 for StudioLive Series III rack mixer firmware update instructions.*
- See Section 3.3 for NSB-series stage box firmware update instructions.*
- See Section 3.4 for EarMix 16M personal monitor mixer firmware update instructions.*
- See Section 3.5 for SW5E AVB switch firmware update instructions.*

2.2 Networking Setup

2.2.1 Control Network - Wired Ethernet

Ethernet cabling.

- Cable length cannot exceed 100M (300') or 7 hops (whichever comes first).
- CAT 5, CAT 7, and CAT 8 cables are not recommended.
- It is recommended all wire and connectors meet or exceed ANSI/TIA-568-C.2 standard.
- Control Network (Select cable type):

Cable Brand Name: _____			
Cable Type	UTP	Shielded	Ethercon
<input type="checkbox"/> CAT 5e	<input type="checkbox"/>	<input type="checkbox"/>	<input type="checkbox"/>
<input type="checkbox"/> CAT 6	<input type="checkbox"/>	<input type="checkbox"/>	<input type="checkbox"/>
<input type="checkbox"/> CAT 6A	<input type="checkbox"/>	<input type="checkbox"/>	<input type="checkbox"/>

2.2.2 Control Network - Wireless (WiFi) Ethernet

- Wireless Router for Control Network**
- Router is exclusive to StudioLive network (Circle One) Yes / No
- Wireless Router Make and Model Number: _____
- Wireless Network Name: _____
- Wireless Network Password: _____
- Wireless Router SSID: _____
- (if applicable) Access Point(s): _____
- Connect router to the primary StudioLive mixer's Control Port. *See Section 4.2 for connection diagram.*
- Use router's LAN ports for connections to any StudioLive Series III Ecosystem Product. Do not use the Main Internet or WAN port.
NOTE: If multiple AVB devices with switch capabilities are plugged into the same router, and the router is also connected to the control port on a console, AVB traffic may be forwarded to the control port of the console which would cause the console to freeze.

- Configure router for DHCP for UC Surface and QMix-UC connectivity.
- Ensure all wireless devices (smartphones, tablets, etc.) are running the latest operating system.
- Ensure all wireless devices (smartphones, tablets, etc.) have the latest version of UC Surface or QMix-UC installed.
- Ensure the wireless control connection is accessible by UC Surface and QMix-UC at all necessary positions in the facility.
- Ensure the wireless channel on the router is free of other wireless traffic.
- Select optimum wireless radio channel that is most likely not to be used by other devices in the same wireless spectrum at same installation.

2.2.3 Networking Setup - Audio Network

Ethernet cabling.

- Cable length cannot exceed 100M (300') or 7 hops (whichever comes first).
- CAT 5, CAT 7, and CAT 8 cables are not recommended.
- It is recommended all wire and connectors meet or exceed ANSI/TIA-568-C.2 standard.
- AVB Network (Select cable type):

Cable Brand Name: _____			
Cable Type	UTP	Shielded	Ethercon
<input type="checkbox"/> CAT 5e	<input type="checkbox"/>	<input type="checkbox"/>	<input type="checkbox"/>
<input type="checkbox"/> CAT 6	<input type="checkbox"/>	<input type="checkbox"/>	<input type="checkbox"/>
<input type="checkbox"/> CAT 6A	<input type="checkbox"/>	<input type="checkbox"/>	<input type="checkbox"/>

- AVB Network Switches
- Use only AVB switches, like the PreSonus SW5E, for all AVB traffic. Note: Do not use Netgear AVB switches.
- Update AVB switch firmware. *See Section 3.5 for SW5E update instructions.*

2.3 Basic StudioLive Mixer Setup

- Set IP Mode to Dynamic (default) either from the console mixer's UCNET screen or Networking tab in the Settings menu in UC Surface.
- Set the permissions for all your remote devices (FOH, All Auxes, etc.).
- For mixers with FOH permissions, enter the default access code in UC Surface (12345).

2.4 Basic NSB Setup

- Update Firmware. *See Section 3.3 for instructions.*
 - Connect NSB stage box to AVB Network.
 - Power the NSB stage box on.
 - Set primary mixer's network clock to "Internal" (default).
 - Route AVB Network streams from mixer to NSB stage box. *Note: An AVB Output source is required for Network clock, even if the NSB stage box outputs are not in use.*
 - Route AVB Network streams from NSB stage box to mixer.
 - Change channel source to "Network" for any mixer channel sourced from the NSB stage box.
- See Section 4.1 for complete set-up instructions.*

2.5 Basic EarMix 16 Setup

- Update Firmware. *See Section 3.4 for instructions.*
- Connect EarMix 16M to AVB Network. *Note: AVB Switches with PoE, like the PreSonus SW5E, will provide power in addition to audio. If PoE is not available, use the included power supply.*
- Power the EarMix 16M on.
- Route AVB Network streams from the mixer to the EarMix 16M. *See Section 4.3 for instructions.*

Note: You must assign an input stream to EarMix 1-8 for proper clocking.

	Model / Device Name	Serial Number	Firmware Version	Date	Location
StudioLive Series III Consoles					
	Model / Device Name	Serial Number	Firmware Version	Date	Location
StudioLive Series III Rack Mixers					
	Model / Device Name	Serial Number	Firmware Version	Date	Location
NSB Stageboxes					
	Model / Device Name	Serial Number	Firmware Version	Date	Location
EarMix 16M					

	Model / Device Name	Serial Number	Firmware Version	Date	Location
<p>SW5E</p> <p>Use the 5 numbered lines to note what piece of equipment is connected to each port on your SW5E.</p>	1.				
	2.				
	3.				
	4.				
	5.				
	1.				
	2.				
	3.				
	4.				
	5.				
	1.				
	2.				
	3.				
	4.				
	5.				
	1.				
	2.				
	3.				
	4.				
	5.				

3 Firmware Update Instructions

3.1 StudioLive Series III Console Mixers

StudioLive Series III console mixers can be updated either by using an SD card loaded with the firmware update file, or by using UC Surface on computer with and without Internet access. These sections will explain both options.

3.1.1 Update Using an SD Card

1. Download the firmware update file for your StudioLive Series III mixer from the My Product page in your My.Presonus account. Please review all instructions before updating your mixer.
2. Open the folder to which you downloaded the .zip firmware file. It will be named with your mixer's model number and the new firmware version (e.g. SL32sIII_1.0.11489.zip).

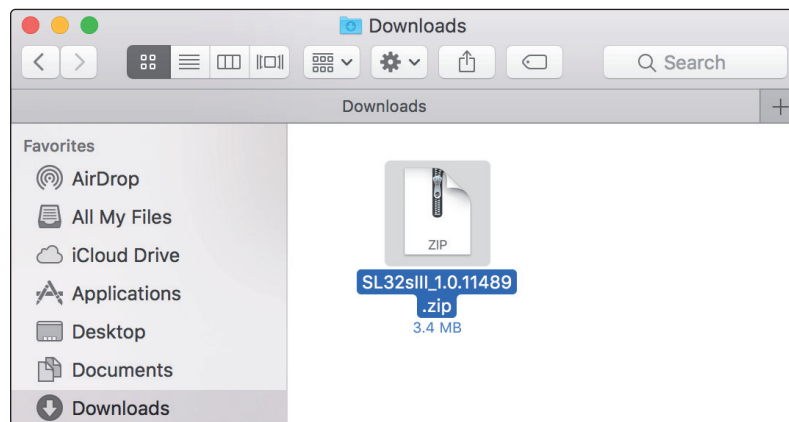

3. Depending on your system preferences, the firmware folder may not automatically decompress the .zip file. To unzip/decompress the file, simply double-click it. On PC, right-click and select **Extract All**.

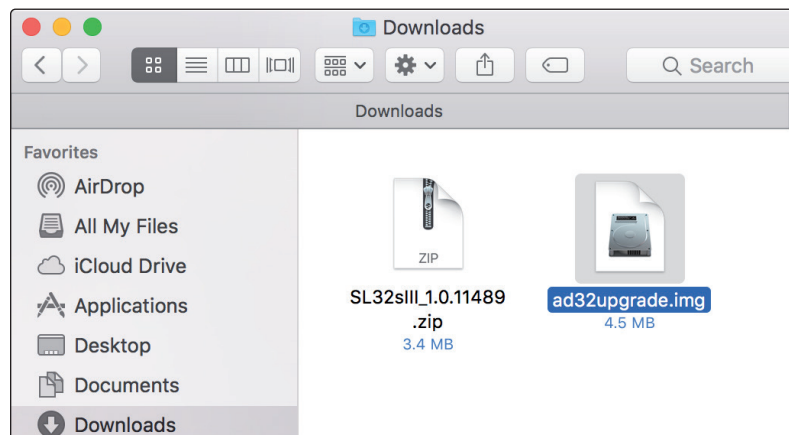

4. In the unzipped folder, you will find the firmware update file. The file will be named as follows:
 - **StudioLive 16:** ad16upgrade.img
 - **StudioLive 24:** ad24upgrade.img
 - **StudioLive 32:** ad32upgrade.img
 - **StudioLive 32SC:** as16_scupgrade.img
 - **StudioLive 32SX:** as24_sxupgrade.img
 - **StudioLive 32S:** as32_supgrade.img
 - **StudioLive 64S:** ad64upgrade.img

5. Select the upgrade file and save it to the root of your SD card. The file must be in the top level of your SD card's directory, not contained in a folder. Once the upgrade file has been saved to your SD card, eject it and remove it from your computer.

6. Power on your mixer and insert the SD card into the SD card slot on the mixer.

7. Press the Home button on your StudioLive Series III mixer.

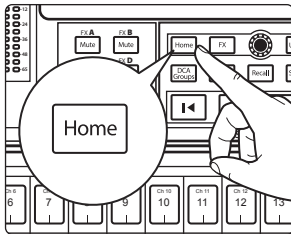

8. Press the System button on your StudioLive Series III mixer touchscreen.

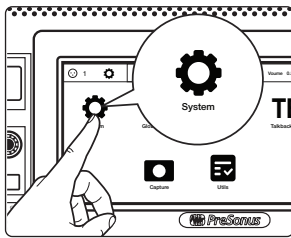

9. Select Firmware from the touchscreen.

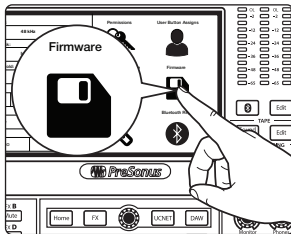

10. Touch the Check for Updates button.

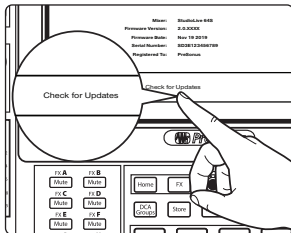

11. When the firmware file has been located on your SD Card, you will be notified. Press Proceed to begin the firmware update.

12. A progress bar will display the firmware update status. When the firmware update is complete finished, the mixer will automatically reboot.

13. Once the mixer has rebooted, confirm the firmware version from the Firmware screen.

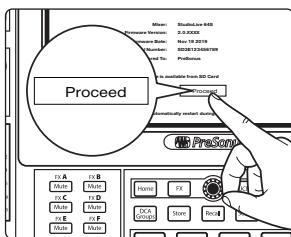

Your StudioLive mixer is now ready to use!

3.1.2 Update from UC Surface (No Internet)

Please Note: While this firmware update method does not require an Internet connection while updating your mixer, an Internet connection is required to download the firmware update file itself.

1. Download the firmware update file for your StudioLive Series III mixer from the My Product page in your My.Presonus account. **Please review all instructions before updating your mixer.**

2. Open the folder to which you downloaded the .zip firmware file. It will be named with your mixer's model number and the new firmware version (e.g. SL32sIII_1.0.11489.zip).

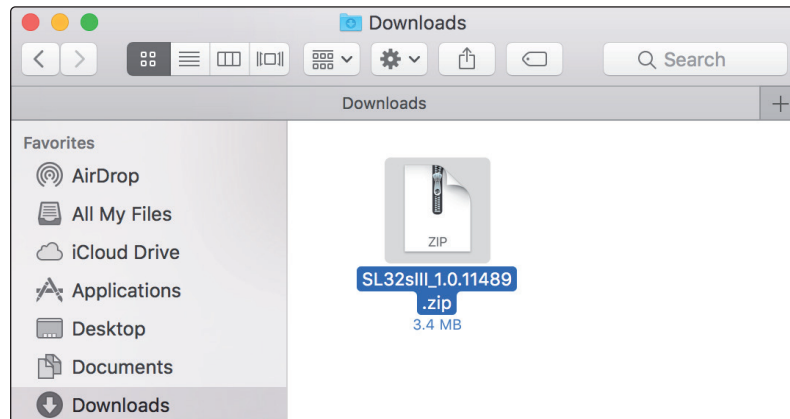

3. Depending on your system preferences, the firmware folder may not automatically decompress the .zip file. To unzip/decompress the file, simply double-click it. On PC, right-click and select **Extract All**.

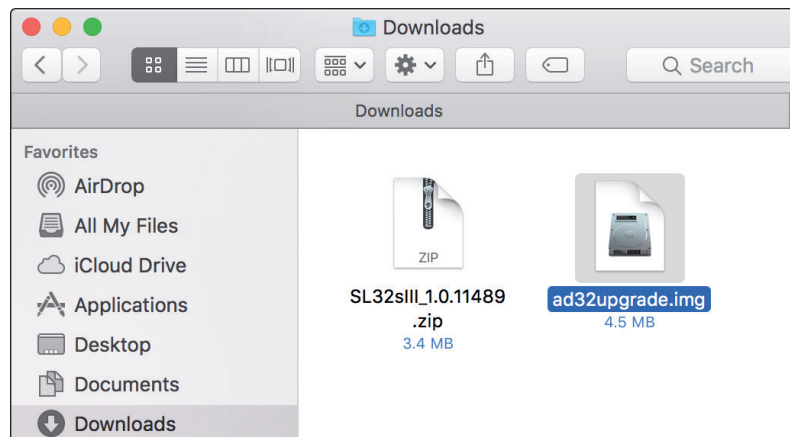

4. In the unzipped folder, you will find the firmware update file. The file will be named as follows:
 - **StudioLive 16:** ad16upgrade.img
 - **StudioLive 24:** ad24upgrade.img
 - **StudioLive 32:** ad32upgrade.img
 - **StudioLive 32SC:** as16_scupgrade.img
 - **StudioLive 32SX:** as24_sxupgrade.img
 - **StudioLive 32S:** as32_supgrade.img
 - **StudioLive 64S:** ad64upgrade.img
5. Open UC Surface and connect to your StudioLive Series III mixer.

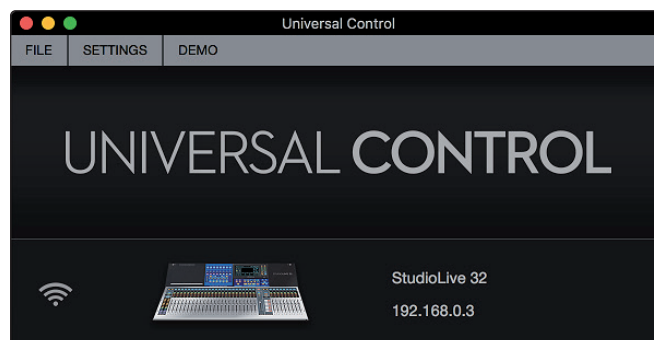

- Click on the Gear icon in the top right corner of the UC Surface window to go to the UC Surface Device Settings page.

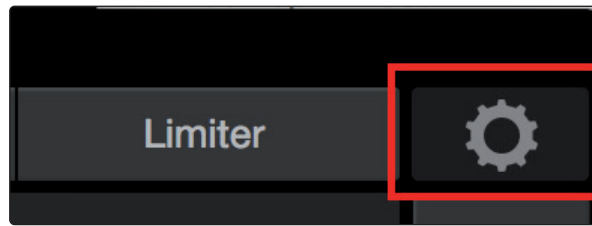

- Select the upgrade file on your computer then drag and drop it on the Version Info section of the Settings page.

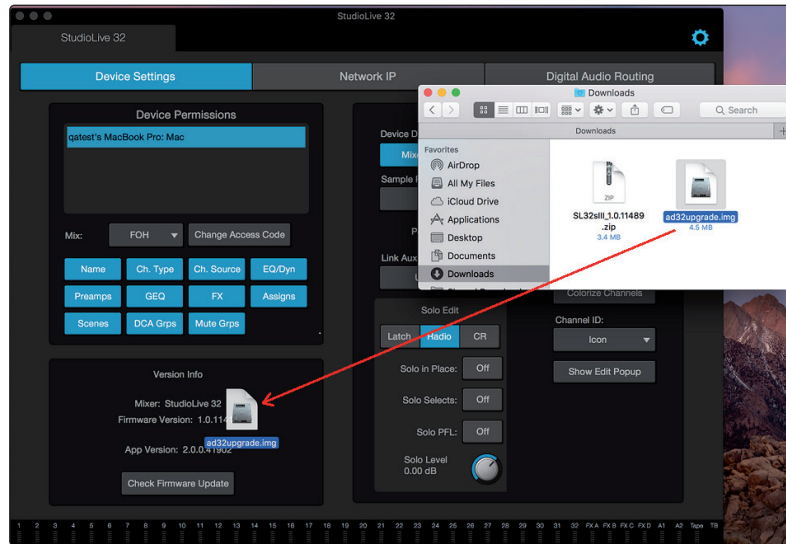

- UC Surface will immediately send the firmware update file to the mixer to begin the firmware update. A progress bar will show on the mixer's screen as the firmware update proceeds. When it is finished, the mixer will automatically reboot.
- Once the mixer has rebooted, confirm the firmware version from the Firmware screen.

Your StudioLive mixer is now ready to use!

3.1.3 Update Using UC Surface (Internet Access)

- On a computer that is connected to the Internet, open UC Surface and connect to your StudioLive Series III mixer.

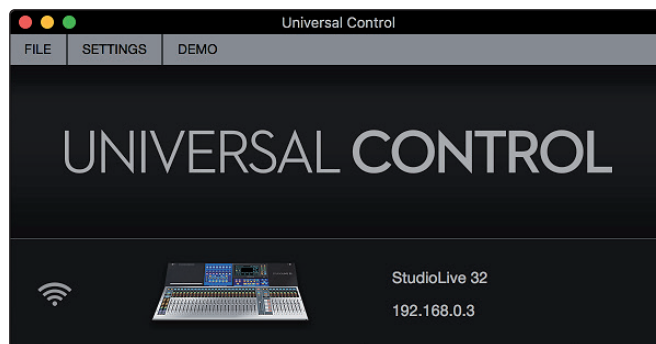

2. Click on the Gear icon in the top right corner of the UC Surface window to go to the UC Surface Device Settings page.

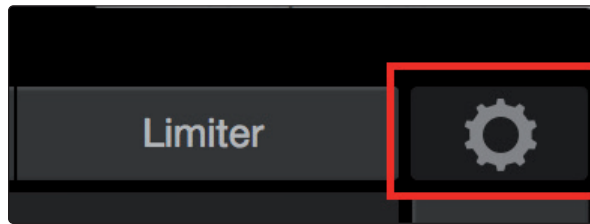

3. In the lower left section under Version Info, click the Check Firmware Update button.

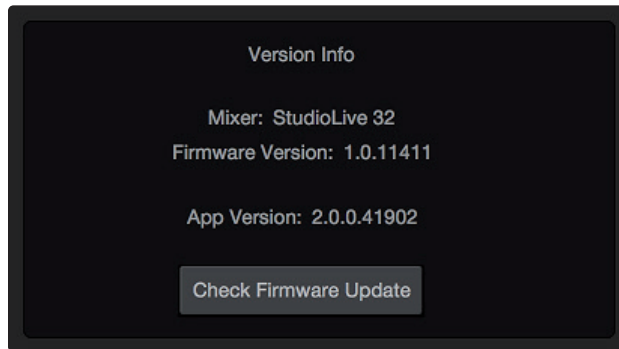

4. UC Surface will connect to your My.PreSonus account and check for an available firmware update.

Note: UC Surface requires access to your PreSonus Account in order to check for and perform the firmware update. The first time you do a network update, you will need to enter the Username and Password for your my.presonus account.

If you have not created a PreSonus User Account with, please do so and make sure your account is activated as well.

5. If there is a firmware update available, you will see the following dialog. Click Yes to continue.

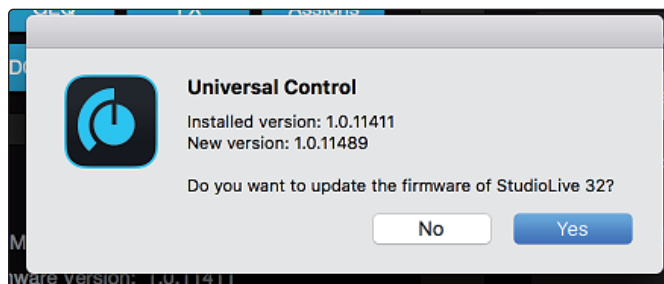

If your mixer's firmware is already up to date, you will see the following dialog. In this case, you do not need to update the mixer's firmware as it is already up to date. You can click OK to close the dialog, or Update Anyway to force a firmware update.

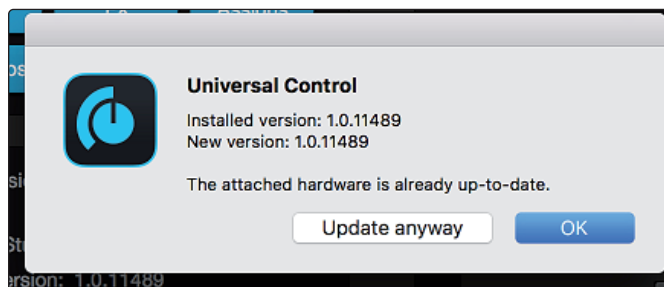

6. Once you begin the update, UC Surface will download the firmware image and then send it to the mixer to be installed.

Note: The firmware image file will be saved to your Downloads folder on your computer. You will now have a local copy of the firmware that you can use at a later time if needed. Because this downloaded firmware image file is renamed, if you want to use it you'll either need to use the UC Surface drag and drop update method, or rename the image file as listed in Sections 2.1.1 and 2.1.2 so you can use the SD card or drag-and-drop to UC Surface update methods.

7. A progress bar will be displayed on the mixer's screen showing the firmware update status. When the firmware update is finished, the mixer will automatically reboot.
8. Once the mixer has rebooted, confirm the firmware version from the Firmware screen.

Your StudioLive mixer is now ready to use!

3.2 StudioLive Series III Rack Mixers

Your StudioLive Series III Rack mixer can be updated in two different ways using the UC Surface software. The following sections will detail each method. Please be review all instructions before updating your StudioLive Series III Rack mixer.

3.2.1 Update Using UC Surface Drag and Drop (No Internet Access)

Please Note: While this firmware update method does not require an Internet connection while updating your mixer, an Internet connection is required to download the firmware update file itself.

1. Download the firmware update file for your StudioLive Series III mixer from the My Product page in your My.Presonus account. Please review all instructions before updating your mixer.
2. Open the folder to which you downloaded the .zip firmware file. It will be named with your mixer's model number and the new firmware version (e.g. SL32sIII_1.0.11489.zip).

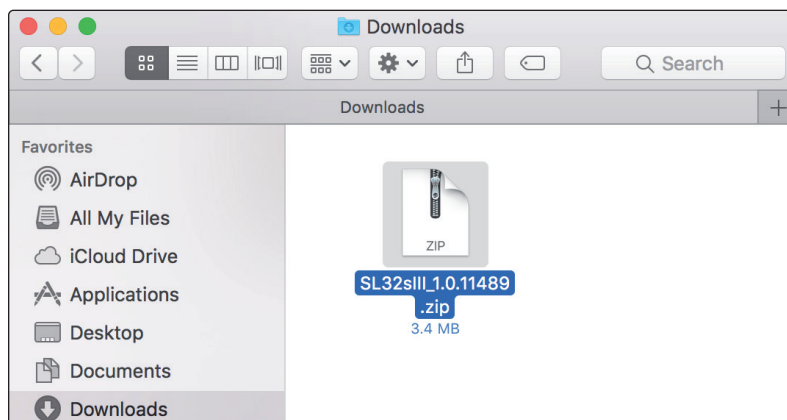

- Depending on your system preferences, the firmware folder may not automatically decompress the .zip file. To unzip/decompress the file, simply double-click it. On PC, right-click and select **Extract All**.

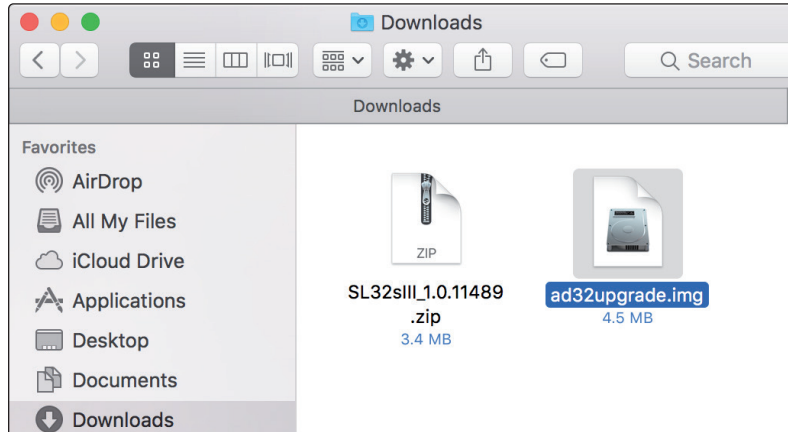

- In the unzipped folder, you will find the firmware update file. The file will be named as follows:
 - StudioLive 16R:** ar16upgrade.img
 - StudioLive 24R:** ar24upgrade.img
 - StudioLive 32R:** ar32upgrade.img
- Open UC Surface and connect to your StudioLive 32R mixer.

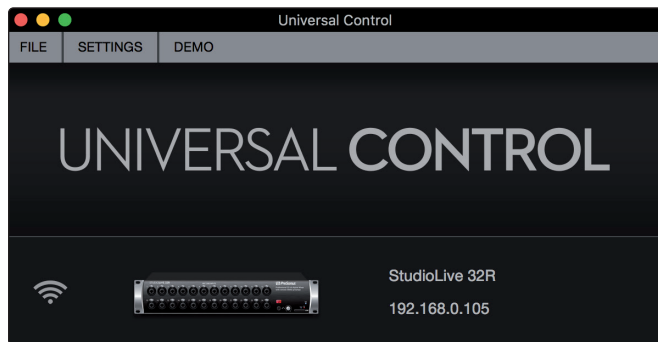

- Click on the Gear icon in the top right corner of the UC Surface window to go to the UC Surface Device Settings page.

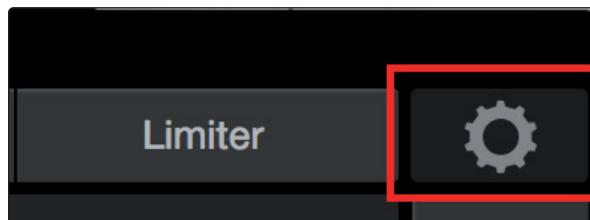

7. Select the upgrade file on your computer and then drag and drop it on the Version Info section of the Settings page.

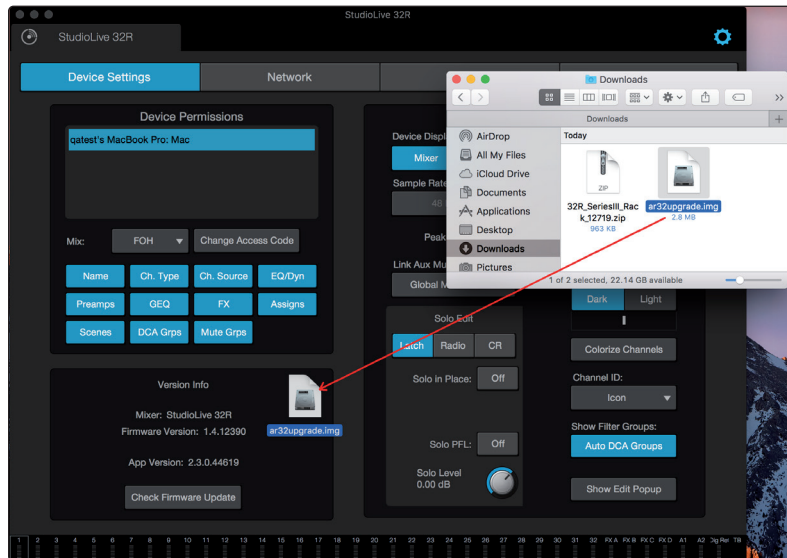

8. UC Surface will immediately send the firmware update file to the mixer and it will begin the firmware update. A progress bar will be displayed in UC Surface showing the firmware update transfer to the mixer.

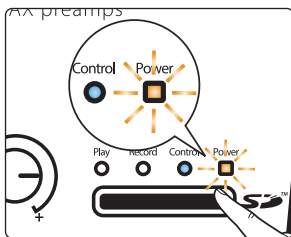

9. As the update proceeds on the mixer, the Control LED on the rack mixer will illuminate solid blue and the Power LED will blink yellow:

Once the update completes, the mixer will automatically reboot.

Note: Update via UC Surface over USB takes noticeably longer than updating with UC Surface over a network connection. It can take up to five minutes, so be patient and allow the mixer to complete the process and reboot. If after five minutes the mixer has not rebooted and the Power LED is still blinking yellow, you may manually power cycle the mixer and check to see if the update has completed. If it has not updated, it is recommended to disconnect USB and connect the mixer to your network via Ethernet instead. Once connected, perform the update from UC Surface over the network connection.

10. Once the mixer has rebooted, confirm the firmware version from the Firmware screen.

Your StudioLive mixer is now ready to use!

3.2.2 Update Using UC Surface (Internet Access)

1. On a computer that is connected to the internet, open UC Surface and connect to your StudioLive 32R mixer.

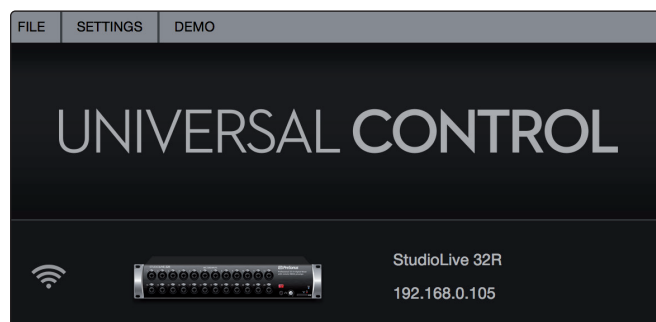

- Click on the Gear icon in the top right corner of the UC Surface window to go to the UC Surface Device Settings page.

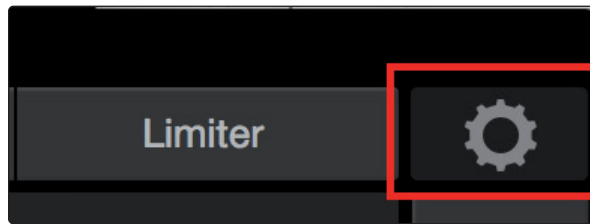

- In the lower left section under Version Info, click the Check Firmware Update button.

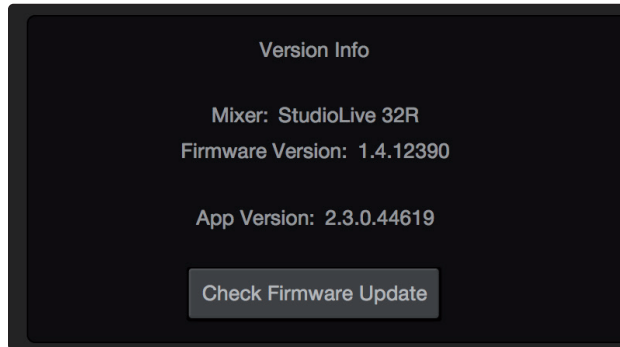

- UC Surface will connect to your My.PreSonus account and check for an available firmware update.

Note: UC Surface requires access to your PreSonus Account in order to check for and perform the firmware update. The first time you do a network update, you will need to enter the Username and Password for your my.presonus account.

If you have not created a PreSonus User Account with, please do so and make sure your account is activated as well.

- If there is a firmware update available, you will see the following dialog. Click Yes to continue.

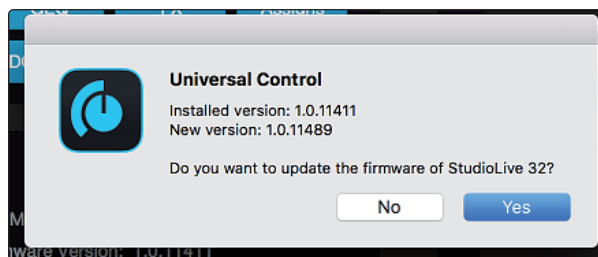

If your mixer's firmware is already up to date, you will see the following dialog. In this case, you do not need to update the mixer's firmware as it is already up to date. You can click OK to close the dialog, or Update Anyway to force a firmware update.

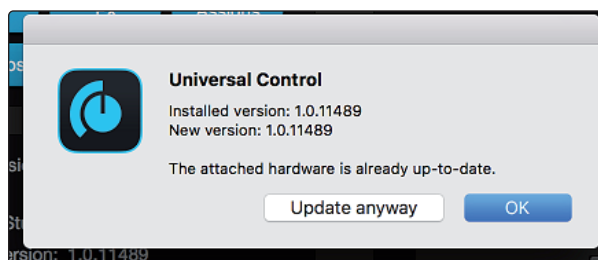

6. Once you begin the update, UC Surface will download the firmware image and then send it to the mixer to be installed.

Note: The firmware image file will be saved to your Downloads folder on your computer. You will now have a local copy of the firmware that you can use at a later time if needed. Because this downloaded firmware image file is renamed, if you want to use it you'll either need to use the UC Surface drag and drop update method, or rename the image file as listed in Sections 2.1.1 and 2.1.2 so you can use the SD card or drag-and-drop to UC Surface update methods.

7. A progress bar will be displayed on the mixer's screen showing the firmware update status.

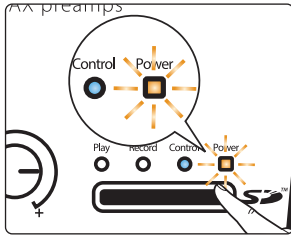

8. As the update proceeds on the mixer, the Control LED on the rack mixer will illuminate solid blue and the Power LED will blink yellow:

Once the update completes, the mixer will automatically reboot.

Note: Update via UC Surface over USB takes noticeably longer than updating with UC Surface over a network connection. It can take up to five minutes, so be patient and allow the mixer to complete the process and reboot. If after five minutes the mixer has not rebooted and the Power LED is still blinking yellow, you may manually power cycle the mixer and check to see if the update has completed. If it has not updated, it is recommended to disconnect USB and connect the mixer to your network via Ethernet instead. Once connected, perform the update from UC Surface over the network connection.

9. Once the mixer has rebooted, confirm the firmware version from the Firmware screen.

Your StudioLive mixer is now ready to use!

3.3 NSB Stage Boxes

To perform a firmware upgrade on your NSB Stage Box, you will need the following:

- NSB 16.8 or NSB 8.8
- A computer (Mac or PC) with the latest Universal Control software (v2.8 or higher). **Note:** If your computer does not have an Ethernet port (i.e. newer MacBooks), then you will need a compatible USB- or Thunderbolt-to-Ethernet adapter for your system.
- Firmware update file (provided inside your product registration on my.presonus.com)

Connecting the NSB to your computer using a router

Simply connect both the NSB and the computer to the router using Ethernet cables. Alternatively, you can connect your computer to the router over WiFi if you prefer. In most cases, it is recommended that you hardwire both the computer and NSB stage box to the router directly.

If your AVB switch has an available port, you can also connect your computer via Ethernet to update your NSB stage box.

Connecting the NSB to your computer directly

For a direct connection using Static Self-Assigned IP's, simply connect the NSB Stage Box to your computer using a standard Ethernet (Cat5e/6) cable. Both the NSB and your computer should assign itself an IP in the same Subnet and Range automatically.

To ensure IP's are in range, continue reading. Otherwise, you can skip to the firmware update instructions.

1. Verify your computer's IP Address:

macOS / OS X

For macOS users, navigate to your Network Preferences utility. You will see a list of available network adapters on the left side of the utility. Once you have connected the Ethernet cable between the computer and switch, macOS will establish a Self Assigned IP Address. The adapter will have an Orange or Yellow color dot indicating this status.

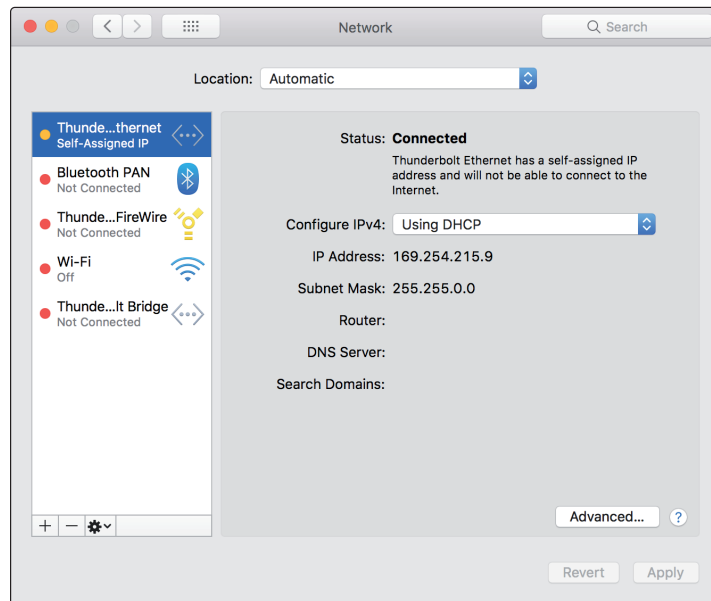

Windows

For Windows users, use the following steps to verify your IP address:

- Press [Windows Key] + [R]
- Type 'cmd' in the text box and press Enter
- In the Terminal window, type 'ipconfig -all'
- You will then see a list of information for your Network Adapters. Locate the IPv4 IP address line for the Network Adapter you are using to connect with.
- When making a direct Ethernet connection, your adapter should self-assign with an IP of [169.254.*.*] **Note:** The asterisk is numbers that the adapter will set. Make sure the first two sets of numbers match.

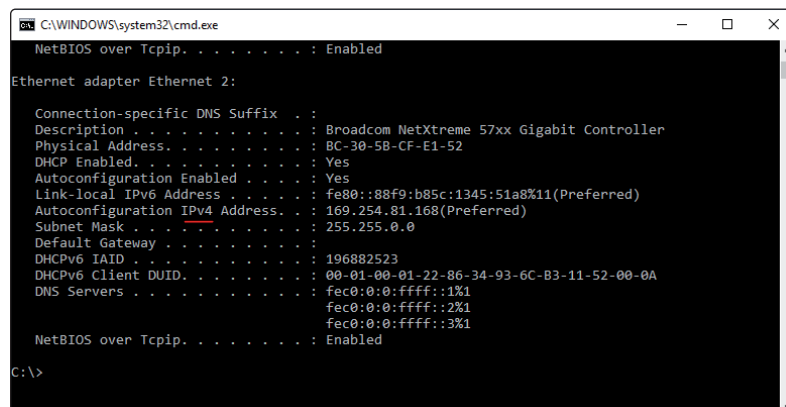

Updating the Firmware via Universal Control

1. Download the firmware update file for your NSB Stage Box from the My Product page in your My.Presonus account. **Please review all instructions before updating your mixer.**
2. After you have networked your NSB stage box to your computer, download and launch Universal Control on your computer. To update the NSB firmware, simply click on the device icon for the NSB stage box you wish to update.

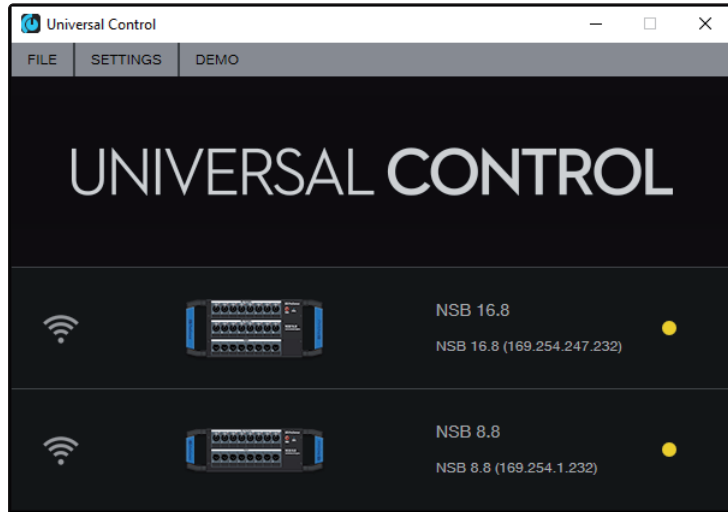

3. At the top of the Universal Control Launch window, you will see the unit's Name, Serial Number, Current Firmware Version. Click on Update Firmware.

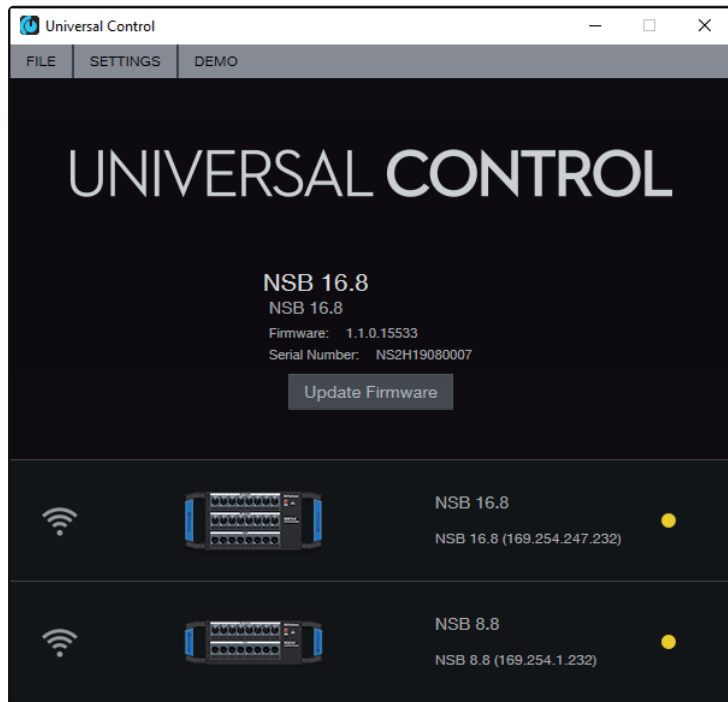

- Once clicked this button, you will be asked to find the firmware file you downloaded. Depending on your system preferences, the firmware folder may not automatically decompress the .zip file. To unzip/decompress the file, simply double-click it. On PC, right-click and select **Extract All**. Make sure this file has been extracted from the compressed file, otherwise Universal Control will not accept the file.

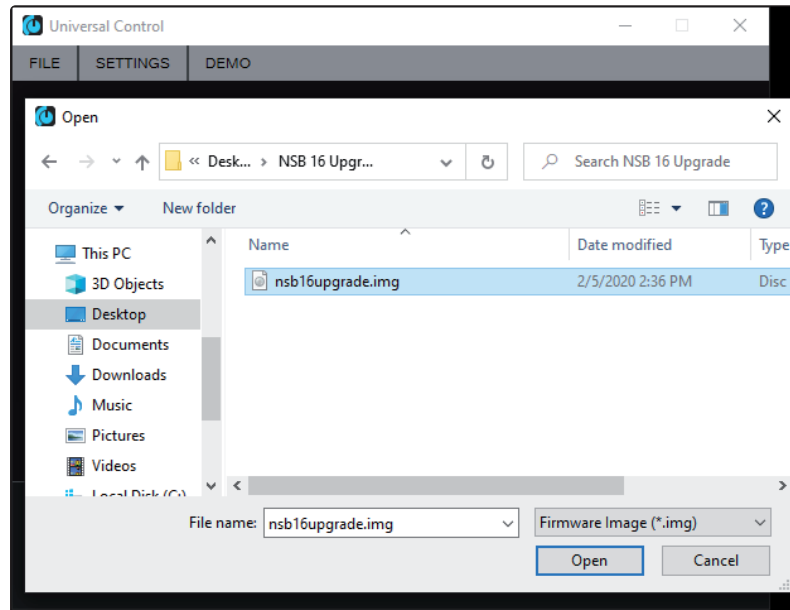

- Once the file is accepted, the update process will start automatically. This process usually takes 1-2 minutes. After completing, the unit will reboot.

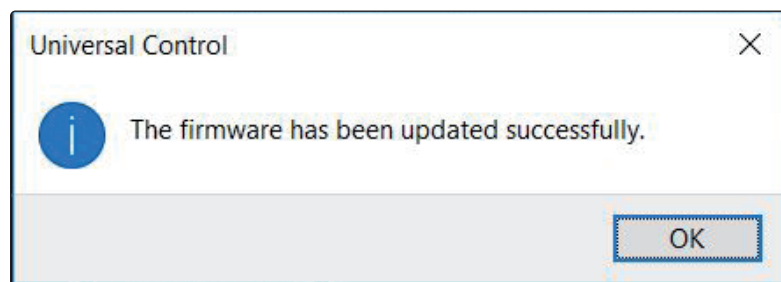
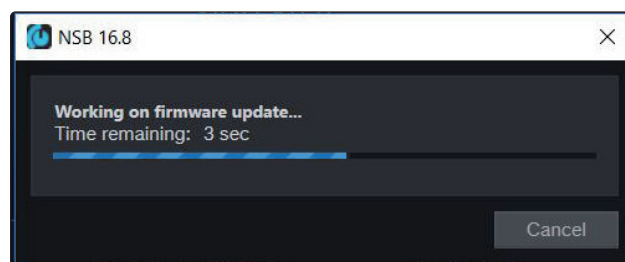

You can verify the update was successful by allowing Universal Control to recognize the rebooted NSB stage box.

Your NSB Stage Box is now ready to use!

⚠ TROUBLESHOOTING TIP: *If the firmware does not 'update,' run the process again. In some very rare cases, the units won't update on the first attempt.*

3.4 EarMix 16M Personal Monitor Mixers

To perform a firmware upgrade on your EarMix 16M personal monitor mixer, you will need the following:

- EarMix 16M Personal Monitor Mixer
- A computer (Mac or PC) with the latest Universal Control software (v2.8 or higher). **Note:** *If your computer does not have an Ethernet port (i.e. newer MacBooks), then you will need a compatible USB- or Thunderbolt-to-Ethernet adapter for your system.*
- Firmware update file (provided inside your product registration on my.presonus.com)

Connecting the EarMix 16M to your computer using a router

Simply connect both the EarMix 16M and the computer to the router using Ethernet cables. Alternatively, you can connect your computer to the router over WiFi if you prefer. In most cases, it is recommended that you hardwire both the computer and NSB stage box to the router directly.

If your AVB switch has an available port, you can also connect your computer via Ethernet to update your EarMix 16M.

Connecting the EarMix 16M to your computer directly

For a direct connection using Static Self-Assigned IP's, simply connect the EarMix 16M to your computer using a standard Ethernet (Cat5e/6) cable. Both the EarMix 16M and your computer should assign itself an IP in the same Subnet and Range automatically.

To ensure IP's are in range, continue reading. Otherwise, you can skip to the firmware update instructions.

1. Verify your computer's IP Address:

macOS / OS X

For macOS users, navigate to your Network Preferences utility. You will see a list of available network adapters on the left side of the utility. Once you have connected the Ethernet cable between the computer and switch, macOS will establish a Self Assigned IP Address. The adapter will have an Orange or Yellow color dot indicating this status.

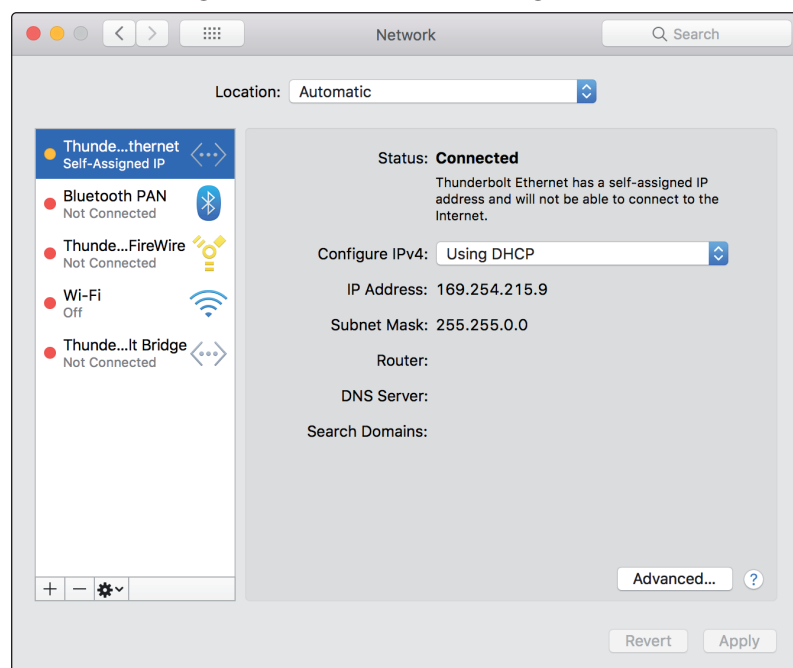

Windows

For Windows users, use the following steps to verify your IP address:

- Press [Windows Key] + [R]
- Type 'cmd' in the text box and press Enter
- In the Terminal window, type 'ipconfig -all'
- You will then see a list of information for your Network Adapters. Locate the IPv4 IP address line for the Network Adapter you are using to connect with.
- When making a direct Ethernet connection, your adapter should self-assign with an IP of [169.254.*.*] **Note:** The asterisk is numbers that the adapter will set. Make sure the first two sets of numbers match.

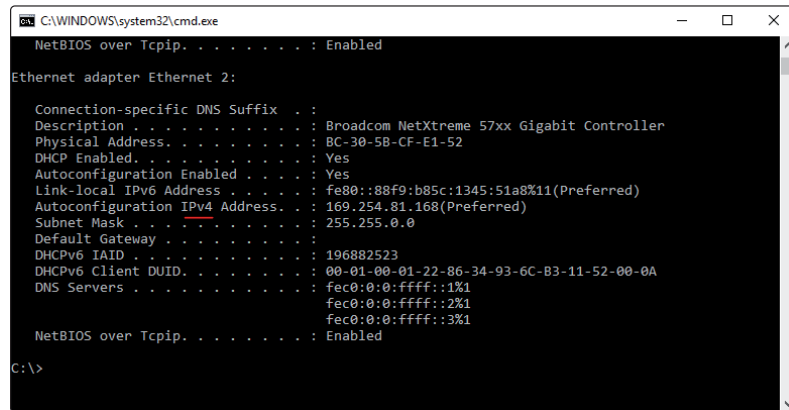

Updating the Firmware via Universal Control

2. Download the firmware update file for your EarMix 16M from the My Product page in your My.Presonus account. Please review all instructions before updating your mixer.
3. After you have networked your EarMix 16M to your computer, download and launch Universal Control on your computer. To update the EarMix 16M firmware, simply click on the device icon for the EarMix 16M you wish to update.

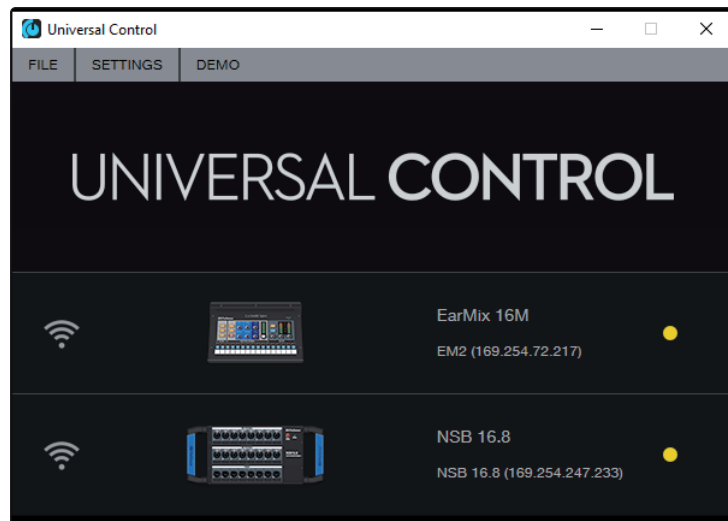

- At the top of the Universal Control Launch window, you will see the unit's Name, Serial Number, Current Firmware Version. Click on Update Firmware.

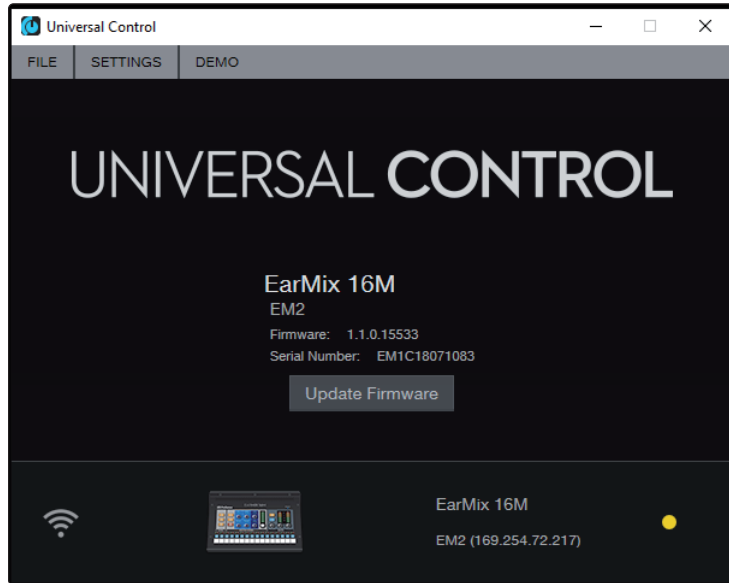

- Once clicked this button, you will be asked to find the firmware file you downloaded. Depending on your system preferences, the firmware folder may not automatically decompress the .zip file. To unzip/decompress the file, simply double-click it. On PC, right-click and select **Extract All**. Make sure this file has been extracted from the compressed file, otherwise Universal Control will not accept the file.

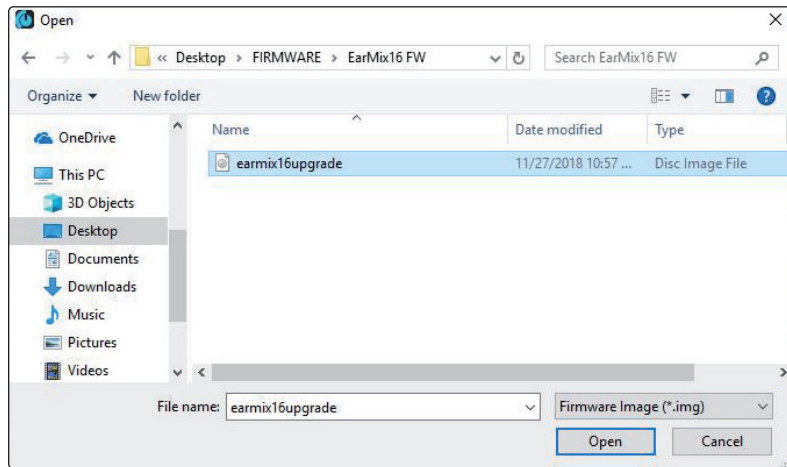

- Once the file is accepted, the update process will start automatically. This process usually takes 1-2 minutes. After completing, the unit will reboot.

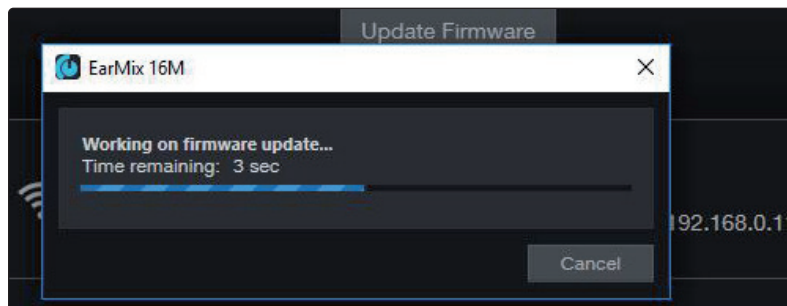

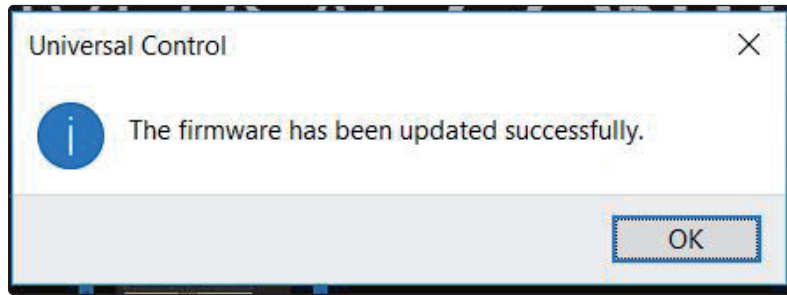

You can verify the update was successful by allowing Universal Control to recognize the rebooted EarMix 16M Personal Monitor Mixer.

Your EarMix 16M Personal Monitor Mixer is now ready to use!



TROUBLESHOOTING TIP: If the firmware does not 'update,' run the process again. In some very rare cases, the units won't update on the first attempt.

3.5 SW5E AVB Switch

At this time, the SW5E is not integrated into Universal Control. The SW5E has a built in Web Tool Interface that provides some basic information of the unit. This interface also facilitates the firmware update process.

Direct Connection with Self Assigned IP's

The SW5E has a default Self Assigned IP Address which is specifically used to connect to the Web Tool Interface.

From the Factory, the default IP is: 169.254.0.1

Simply connect an Ethernet cable between your computer and the SW5E (any port will work).

Note: Newer Apple Laptops and some PC laptops may not have an Ethernet port. USB or Thunderbolt to Ethernet adapter may be required.

DHCP Connection (Router provided IP's)

For users that have DHCP on their AVB network (Router linked to Switch), it is possible to access the Web Tool Interface on the SW5E.

Note: The computer and the SW5E switch should be wired directly to the Router's LAN ports.

You will need to find the assigned IP address of the SW5E. Most, if not all, routers will have a web based utility to access the Router's internal settings interface. Within this, there is a DHCP Client list (or similar name) that shows all connected clients of the Router. This list will show Device name, MAC Addresses, Current Assigned IP, and possibly other information.

Once you find this information, you should see the SW5E listed with its current IP. Use that IP to connect to the SW5E Web Tool Interface.

Note: You will need to know your Router's Admin Username / Password to access, and will need to refer to your specific Router's Manual on how to access the Router's Settings page and to navigate to its DHCP Client list.

Verify your computer's IP Address

Note: If your computer is also connected to a wireless network, this network connection may be given priority over the SW5E. Because of this, it is recommended that Wi-Fi be turned off while updating the SW5E.

macOS / OS X

For macOS users, navigate to your Network Preferences utility. You will see a list of available network adapters on the left side of the utility. Once you have connected the Ethernet cable between the computer and switch, macOS will establish a Self Assigned IP Address. The adapter will have an Orange or Yellow color dot indicating this status.

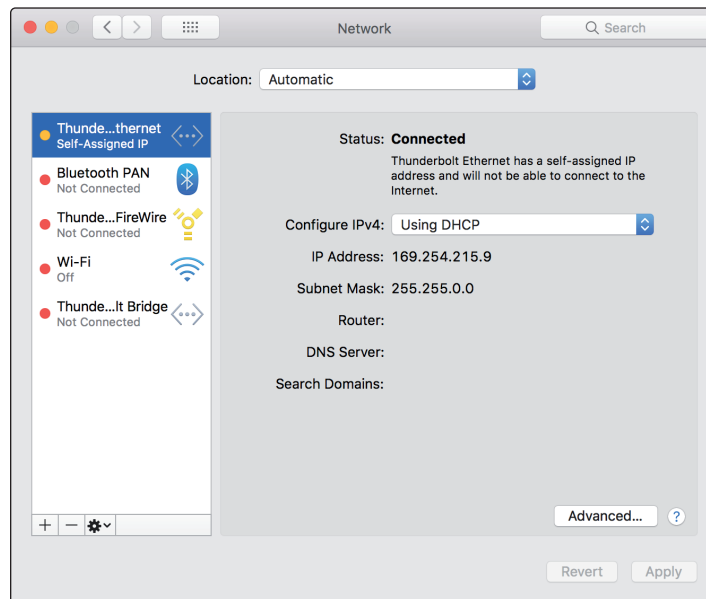

Windows

For Windows users, use the following steps to verify your IP address:

- Press [Windows Key] + [R]
- Type 'cmd' in the text box and press Enter
- In the Terminal window, type 'ipconfig -all'
- You will then see a list of information for your Network Adapters. Locate the IPv4 IP address line for the Network Adapter you are using to connect with.
- When making a direct Ethernet connection, your adapter should self-assign with an IP of [169.254.*.*] **Note:** The asterisk is numbers that the adapter will set. Make sure the first two sets of numbers match.

Connecting to the Web Tool Interface

Once you have verified that your computer has set a Self Assigned IP Address, open any web browser of your choice.

In the address bar, type the following IP and press Enter: 169.254.0.1

Note: use the IP address shown in the device list for your router when using DHCP.

This will immediately bring you to the Web Tool Interface.

Updating SW5E Firmware

1. Download the Firmware Update file from your My.PreSonus account. This file will be available under your Registered SW5E product downloads section.
2. At the bottom of the Web Tool Page, you will find a button for to locate the firmware file on your computer. Click the 'Choose Firmware' button, then navigate to the location on the hard drive to select the file.

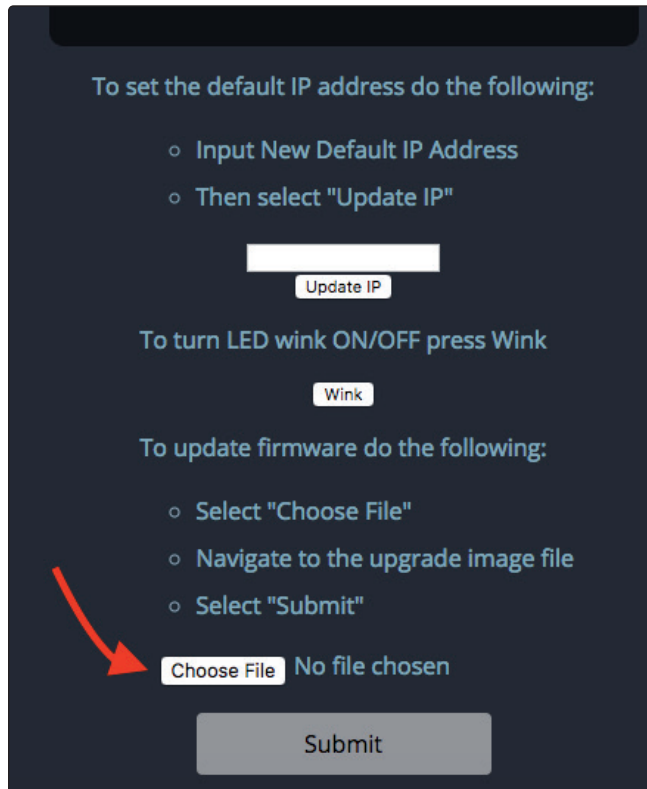

3. After selecting the file, press the Submit button to engage. This will bring you to another page. Wait 10 seconds, then press the back button and refresh the page (or simply type the IP address again).

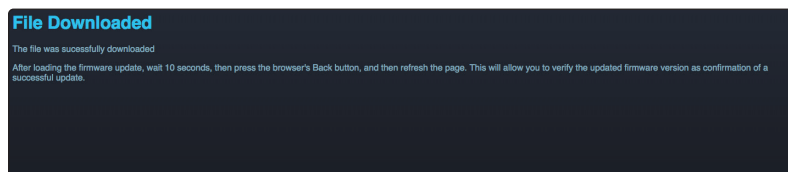

4. The Web Tool Interface will refresh and you'll notice that the Firmware Version number has changed, indicating that the process has completed.

3.5.1 Additional Web Tool Interface Features

After completing the update: if you're coming from version 1.0, you will notice that there are two additional functions available for the SW5E AVB Switch.

Default IP Address

This allows you to change the Default Self Assigned IP that the switch uses to allow connections to the remote Web Tool Interface. This is for users that have more than one SW5E on an AVB Network and they want to set a specific address for that unit.

Power User Tip: *This address does not work when the switch has been assigned an IP through DHCP (Router). You must use the IP that DHCP assigns.*

*It is recommended that the new IP address be written either on the unit or another secure location so that you do not forget the new IP address. We recommend only changing the Default IP when **absolutely necessary**. Otherwise, use the provided default IP.*

Wink

When you have more than one switch on a network, you can use the Wink feature to identify which switch you have connected to. The Front Network LED lights will flash in sync briefly, letting you know which unit it is.

4 Applications

4.1 StudioLive Series III Console Mixer with NSB Stage Box

Connect your NSB stage box to your StudioLive console mixer either using an AVB switch or connected directly as shown below:

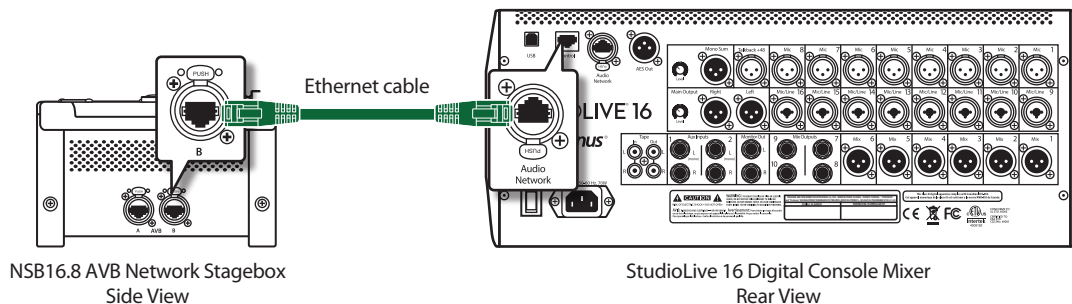

Before continuing verify the following:

- Your stage box is connected to the Audio Network port on your StudioLive console mixer.
- Your mixer and your stage box have been updated to the latest firmware.

Step 1: Confirm Proper Network Clock

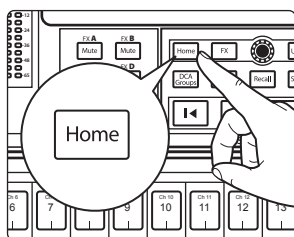

1. Press the Home button on your StudioLive Series III mixer.

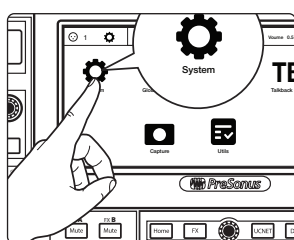

2. Press the System button on your StudioLive Series III mixer touchscreen.

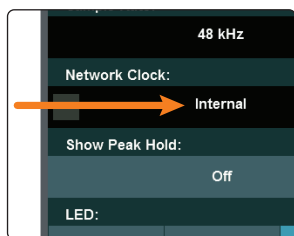

3. The Network clock should be set to Internal.

Note: If there is more than one mixer on the network, the main mixer should be set to Internal. All other mixers should be set to Network Stream.

Step 2: Connect Your Stage Box to Your Mixer

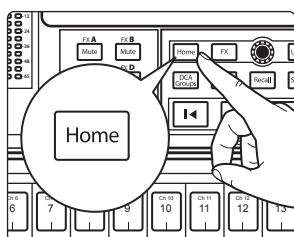

1. Press the Home button on your StudioLive Series III mixer.

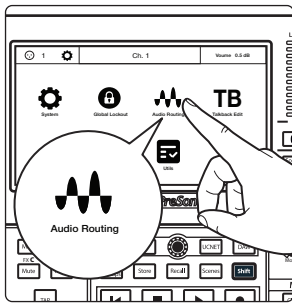

2. Press the Audio Routing icon on the Touchscreen.

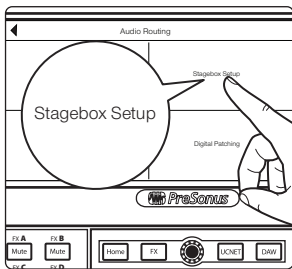

3. Press the Stagebox Setup button on the Touchscreen.

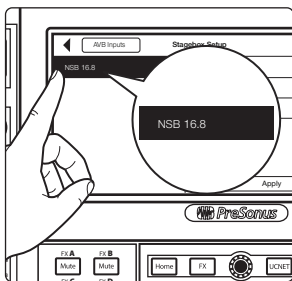

4. Select the NSB stage box from the list on the left.

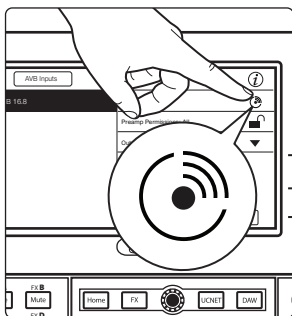

Power User Tip: In applications where you are using multiple NSB-series stage boxes of the same model, you can press the Identify button. This will flash the Power Network LED on the front of the selected NSB stage box from green to red, allowing you to quickly locate your selection. You can also rename the NSBs from this screen by touching the NSB name to the immediate left of the Identify button.

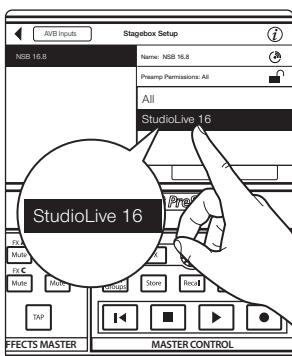

5. Select the mixer you'd like to use to control the preamps on your NSB stage box. By default, this is set to "All", enabling any StudioLive Series III mixer on the AVB network to control the preamps on your stage box.

Power User Tip: Because your NSB stage box inputs are most likely routed to multiple sources on your network, PreSonus highly recommends designating one mixer to control the NSB preamps.

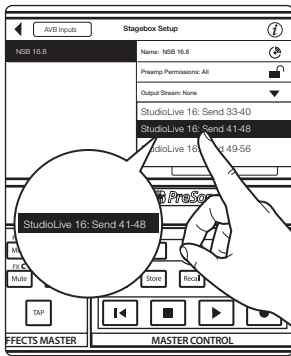

6. Select the AVB Output Sends you'd like returned to the physical outputs on your NSB stage box. Because the AVB streams must be routed in banks of 8, you can only source these outputs from one mixer on the network.

Important: You must assign an output stream from your mixer to your NSB-series stage box so that it is clocked properly over the network. If you do not assign an output stream from your mixer, your networked stage box will not be properly synced and you will hear audio artifacts. For more information on clocking over AVB, please review the AVB Networking Guide.

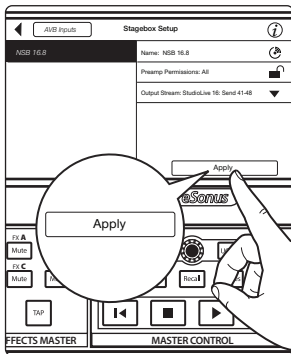

7. Press the Apply button when finished.

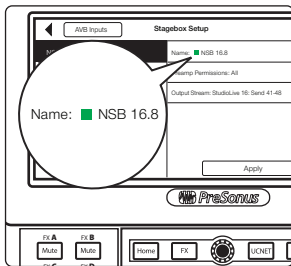

Power User Tip: Once send streams from your mixer have been successfully patched, you will see a green status indicator next to your NSB stage box in the setup screen. The light on the front of the NSB will also turn blue, indicating that clock is synced between the mixer and the NSB.

Step 3: Routing Stage Box Inputs to Mixer

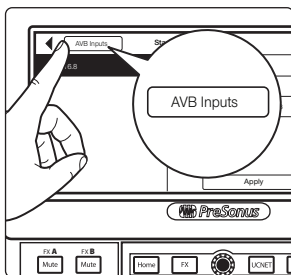

1. Press the AVB Inputs button.

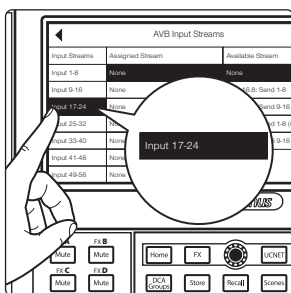

2. Select the desired bank of AVB inputs on your mixer from the Input Streams list.

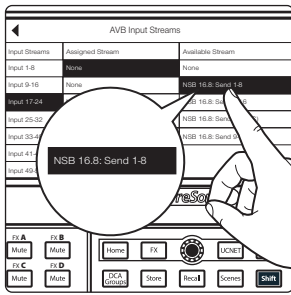

3. Select desired NSB AVB Sends from the Available Stream list to patch the corresponding physical NSB inputs to the desired channels on your mixer.

Note: NSB stage boxes have two sets of streams: one with Gain Compensation and one without. In our example, the StudioLive 16 has total preamp control over the NSB stage box and is the only mixer connect to its streams. **Please review Section 3** in the NSB Owners Manual for more information on Gain Compensation and when it is advantageous or even required.

Step 5: Engage Network Sources

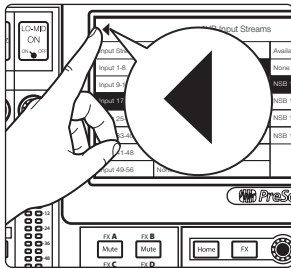

1. Press the back arrow twice to return to the Audio Routing screen.

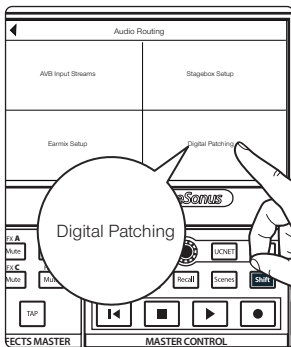

2. Press Digital Patching.

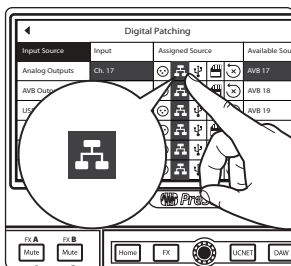

3. Select Input Source and scroll to Inputs 17-32. Assign each to the Network source by pressing the Network button next to each Input.

OR

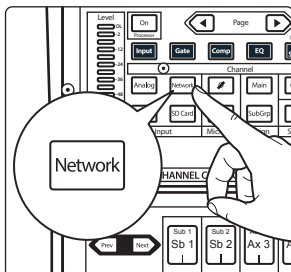

Select each channel and press the Network button from the Input source section in the Fat Channel. To assign multiple Network sources at once, press and hold the Network button until the Select buttons flash, then press the Select button for every channel for which a Network source should be engaged. This will patch the Network source on each channel you select.

Your NSB is now ready to use!

4.2 StudioLive Series III Console with Rack Mixer

Connect your StudioLive rack mixer to your StudioLive console mixer either using an AVB switch or connected directly as shown below:

Direct connection

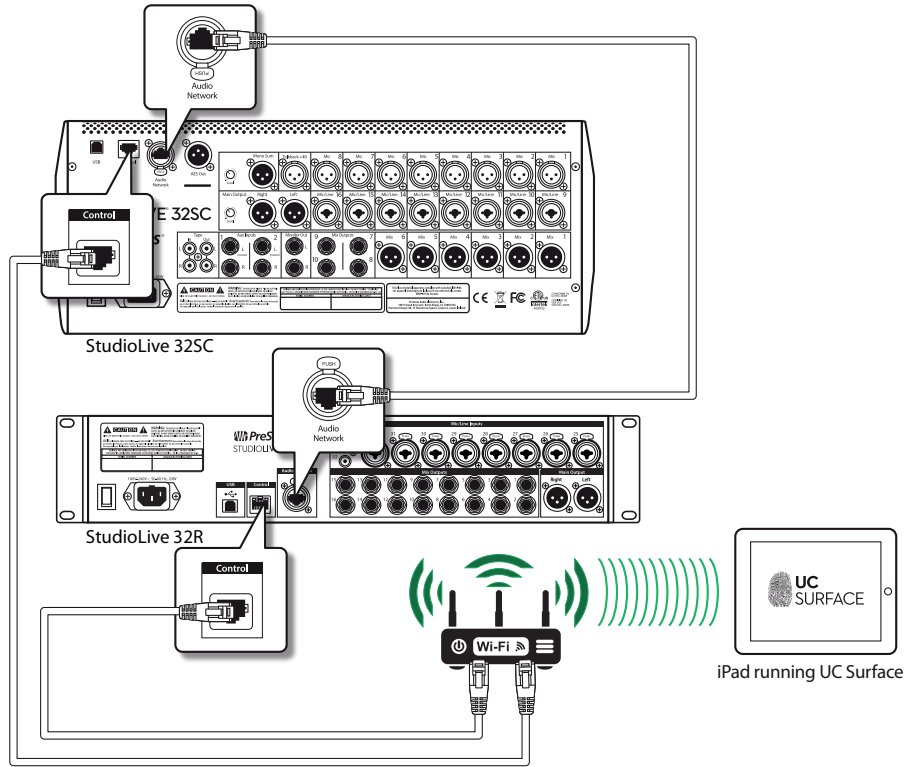

Connect using an AVB switch

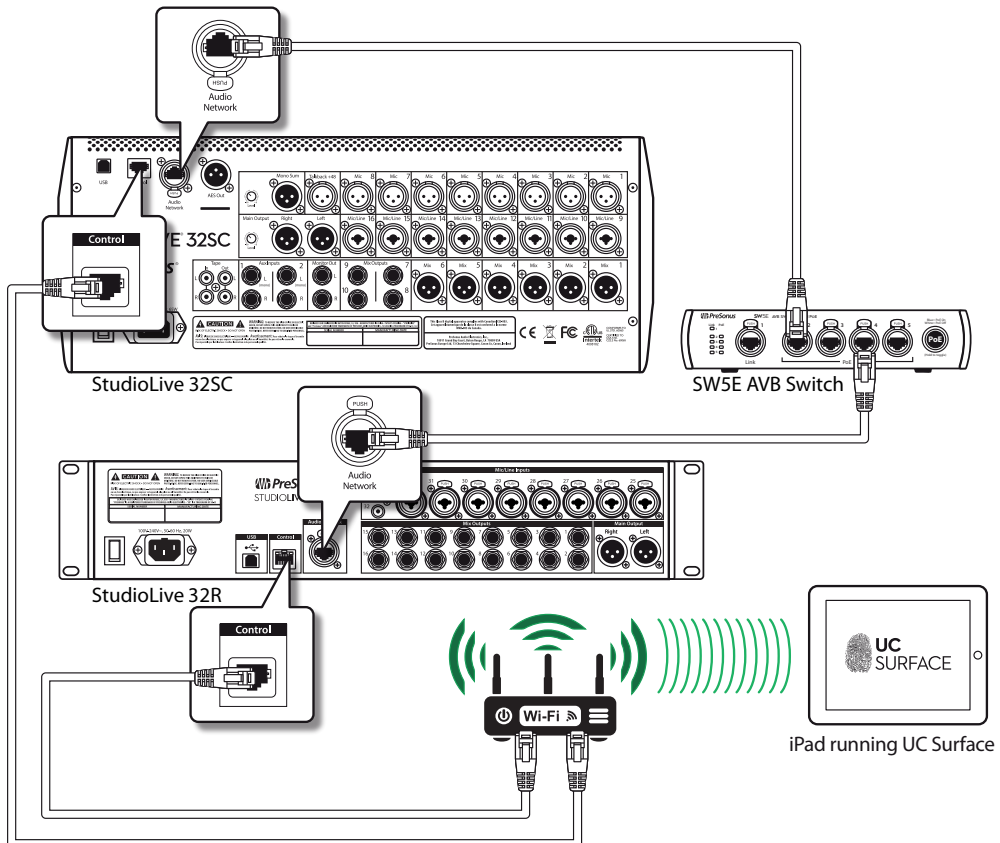

Before continuing verify the following:

- Both mixers are connected via the Audio Network port.
- Both mixers have been updated to the latest firmware.

Step 1: Confirm Proper Network Clock

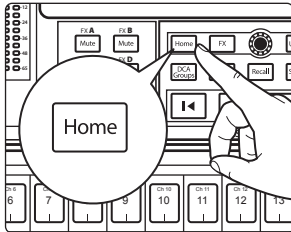

1. Press the Home button on your StudioLive Series III console mixer.

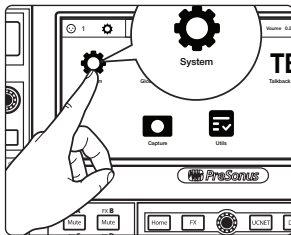

2. Press the System button on your StudioLive Series III mixer touchscreen.

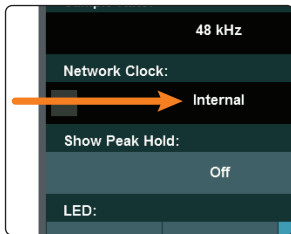

3. The Network clock should be set to Internal.

Step 2: Connect your mixers over AVB

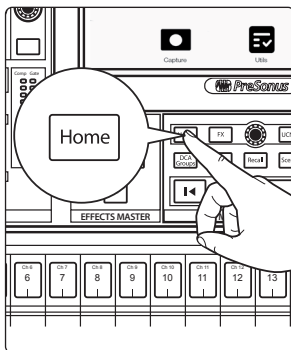

1. Press the Home button on your StudioLive Series III console.

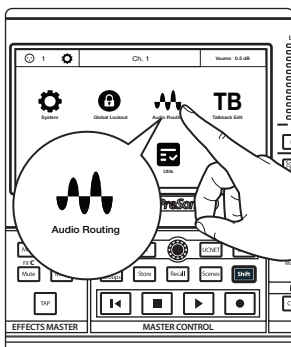

2. Press Audio Routing on the Home Screen.

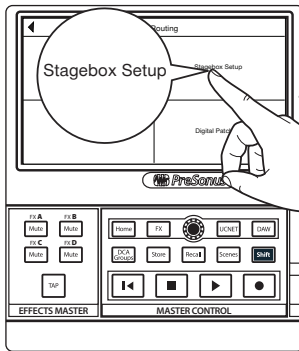

3. Press the Stagebox Setup button on the screen.



4. Select your rack mixer from list at the left.

If you have more than one rack mixer connected to the network and are unsure which mixer is which, you can press the Identify button. This will flash the front panel LEDs on whichever mixer is currently selected.

See Section 2.2.1 to complete Monitor Mixer Mode Setup.

See Section 2.2.2 to complete Stagebox Mode Setup.

4.2.1 Monitor Mixer Mode



After completing the steps in **Section 4.2**, select Monitor Mixer Mode for your rack mixer from the Stagebox Setup screen on your StudioLive console mixer.

Step 1: Set Preamp Permissions

The preamps on StudioLive rackmount mixer can be controlled from any StudioLive Series III mixer on the network. When you have a StudioLive rackmount mixer in monitor mix mode feeding more than one mixer, it is recommended that you give only one mixer permission to adjust the StudioLive rackmount mixer preamp levels.

From the Stagebox Setup menu, select your rackmount mixer and then tap the arrow next to Preamp Permissions menu to select the mixer from which you would like to control your StudioLive rackmount mixer preamps.

In most cases, you will want to give Preamp Permissions to the FOH StudioLive console. This allows the FOH console to control overall gain, while providing 40 dB (-20 dB to +20 dB) digital gain for the Monitor Mixer Mode mixer

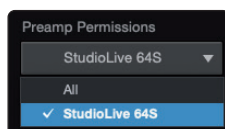
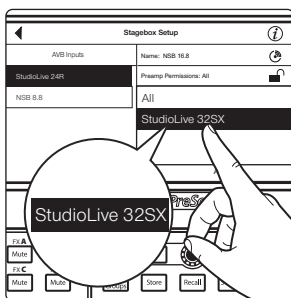

Preamp permissions can also be set from the Stagebox Setup area on the Network tab in the Settings menu in UC Surface.

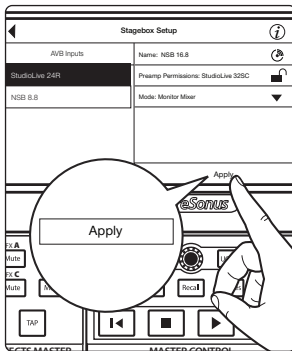

Tap Apply to save the mode and the preamp permissions.

Power User Tip: Connecting to your mixer and selecting the mode can be one or two steps. When Apply is pressed, both the selected mixer for preamp permissions and the selected Stagebox Mode are saved simultaneously.

Step 2: Routing AVB Inputs

StudioLive Series III mixers route channels in banks of 8. Once Monitor Mixer has been enabled, your mixers will be auto-configured as follows:

StudioLive 32R and 24R:

- **Monitor Mixer Mode.** Inputs 1-32 will be routed between the two networked mixers so that they are available on both. The Main Mix and will be routed from the console mixer to the rack mixer but the Flex Mixes will remain local to each mixer.

StudioLive 16R:

- **Monitor Mixer Mode.** Inputs 1-16 will be routed between the two networked mixers so that they are available on both. The Main Mix and will be routed from the console mixer to the rack mixer, but the Flex Mixes will remain local to each mixer.

For information on changing default AVB routing, please see Section 2.2.3.

Step 3: Engage Network Sources

Once channels have been patched between your StudioLive Series III rackmount mixer to your StudioLive Series III console mixer, they can be accessed by selecting the Network input as the source on either mixer. For example, if you would like Channel 1 on your console mixer to be sourced from Channel 1 on your rack mixer, you must select Network as the input source on your console mixer. In this way, you can access local analog, network, USB, or SD input sources for each channel as needed.

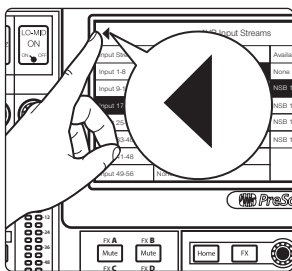

1. Press the back arrow twice to return to the Audio Routing screen.

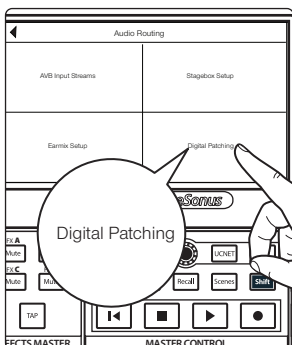

2. Press Digital Patching.

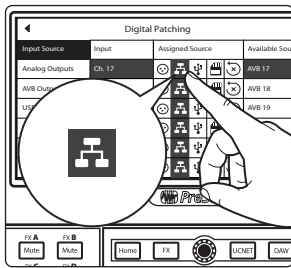

3. Select Input Source and scroll to the desired channels. Assign each to the Network source by pressing the Network button next to each Input.

OR

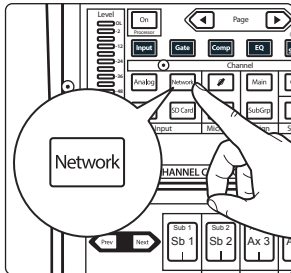

Select each channel and press the Network button from the Input source section in the Fat Channel. To assign multiple Network sources at once, press and hold the Network button until the Select buttons flash, then press the Select button for every channel for which a Network source should be engaged. This will patch the Network source on each channel you select.

Your StudioLive mixers are now ready to use!

4.2.2 Stagebox Mode

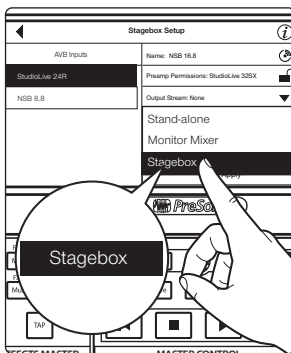

1. After completing the steps in *Section 4.2*, select Stagebox Mode.

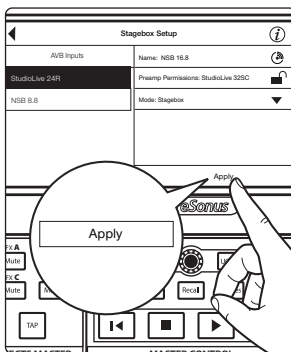

2. Tap Apply to save the mode.

Power User Tip: Connecting to your mixer and selecting the mode can be one or two steps. When Apply is pressed, both the selected mixer and the selected Stagebox Mode are saved simultaneously.

Step 1: Routing AVB Inputs

StudioLive Series III mixers route channels in banks of 8. Once Stage Box Mode has been enabled, your mixers will be auto-configured as follows:

StudioLive 32R and 24R:

- **Stage Box Mode.** Inputs 1-32 will be routed between the two networked mixers so that they are available on both. The Main Mix and Flex Mixes 1-16 will be routed from the console mixer to the rack mixer.

StudioLive 16R:

- **Stage Box Mode.** Inputs 1-16 will be routed between the two networked mixers so that they are available on both. The Main Mix and Flex Mixes 1-6 will be routed from the console mixer to the rack mixer.

For information on changing the Default routing, please see *Section 2.2.3*

Step 2: Engage Network Sources

Once channels have been patched between your StudioLive Series III rackmount mixer to your StudioLive Series III console mixer, they can be accessed by selecting the Network input as the source on either mixer. For example, if you would like Channel 1 on your console mixer to be sourced from Channel 1 on your rack mixer, you must select Network as the input source on your console mixer. In this way, you can access local analog, network, USB, or SD input sources for each channel as needed.

1. Press the back arrow twice to return to the Audio Routing screen.

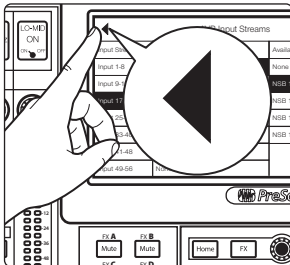

2. Press Digital Patching.

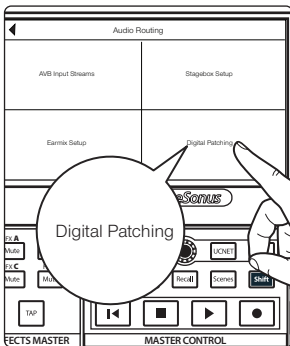

3. Select Input Source and scroll to the desired inputs. Assign each to the Network source by pressing the Network button next to each Input. To assign multiple Network sources at once, press and hold the Network button until the Select buttons flash, then press the Select button for every channel for which a Network source should be engaged. This will patch the Network source on each channel you select.

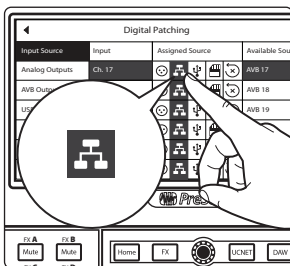

OR

Select each channel and press the Network button from the Input source section in the Fat Channel. To assign multiple Network sources at once, press and hold the Network button until the Select buttons flash, then press the Select button for every channel for which a Network source should be engaged. This will patch the Network source on each channel you select.

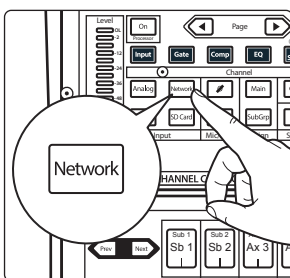

Your StudioLive mixers are now ready to use!

4.2.3 Editing Default AVB Inputs

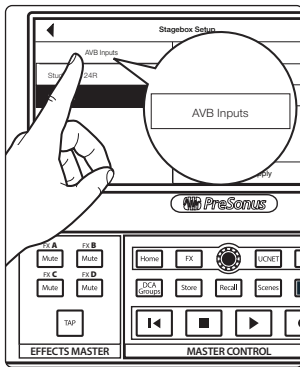

To edit the default AVB Routing between your two mixers, press the AVB Inputs button on the Touchscreen.

This will open the AVB Input Streams menu.

Input Streams	Assigned Stream	Available Stream
Input 1-8	StudioLive 16R: Output 1-8	None
Input 9-16	StudioLive 16R: Output 9-16	StudioLive 16R: Output 1-8
Input 17-24	StudioLive 16R: Output 17-24	StudioLive 16R: Output 9-16
Input 25-32	StudioLive 16R: Output 25-32	StudioLive 16R: Output 17-24
Input 33-40	StudioLive 16R: Output 33-40	StudioLive 16R: Output 25-32
Input 41-48	StudioLive 16R: Output 41-48	StudioLive 16R: Output 33-40
Input 49-56	StudioLive 16R: Output 49-56	StudioLive 16R: Output 41-48

The Input Stream list and the Available Stream list can be scrolled by touching the list header or anywhere in the list and turning the encoder under the screen. Inputs 57-64 do not show until you scroll down. To change a routing, press the Input Stream to which you'd like to route and then use the value encoder to scroll through the Available Streams list on the right. Tap on the desired routing to patch it.

Once an AVB Output Stream from the rackmount mixer is routed to an AVB Input on the console mixer, it cannot be routed to another input stream.

4.2.4 Preamp Control

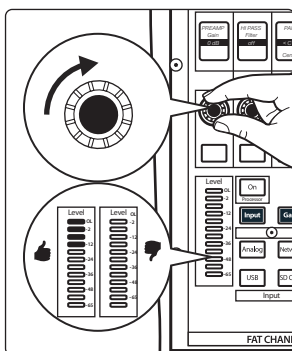

Once the Network input has been selected on the StudioLive Series III console mixer, you can remote control the preamp level and phantom power for your rackmount mixer from the top panel of your console mixer.

4.3 StudioLive Series III Consoles: FOH and Monitor Mixer Mode

Connect your StudioLive console mixers either using an AVB switch or connected directly as shown below:

Direct connection

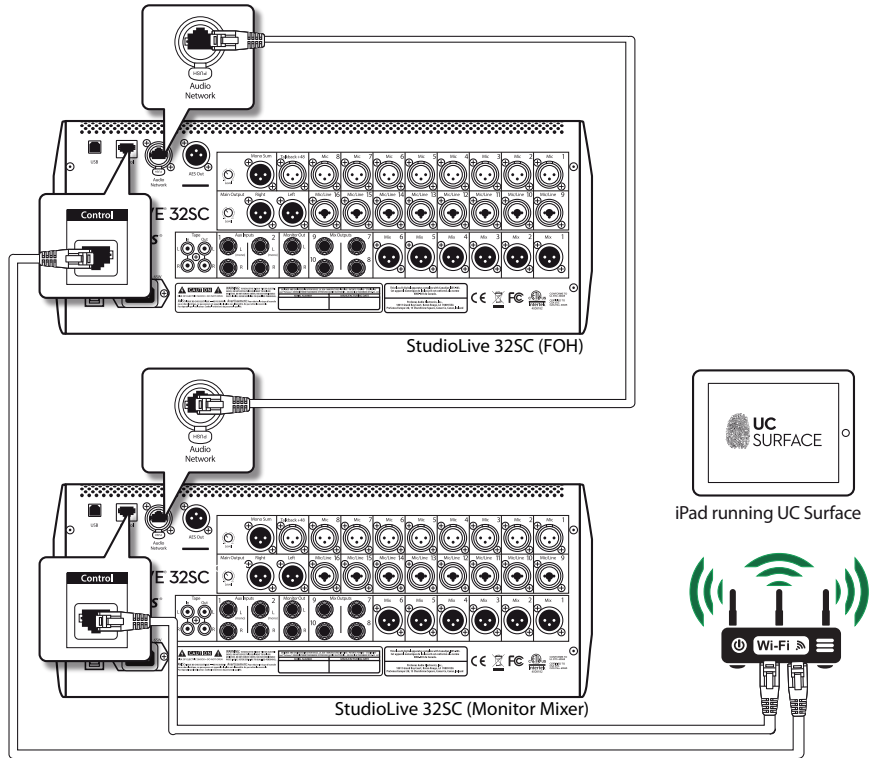

Connect using an AVB switch

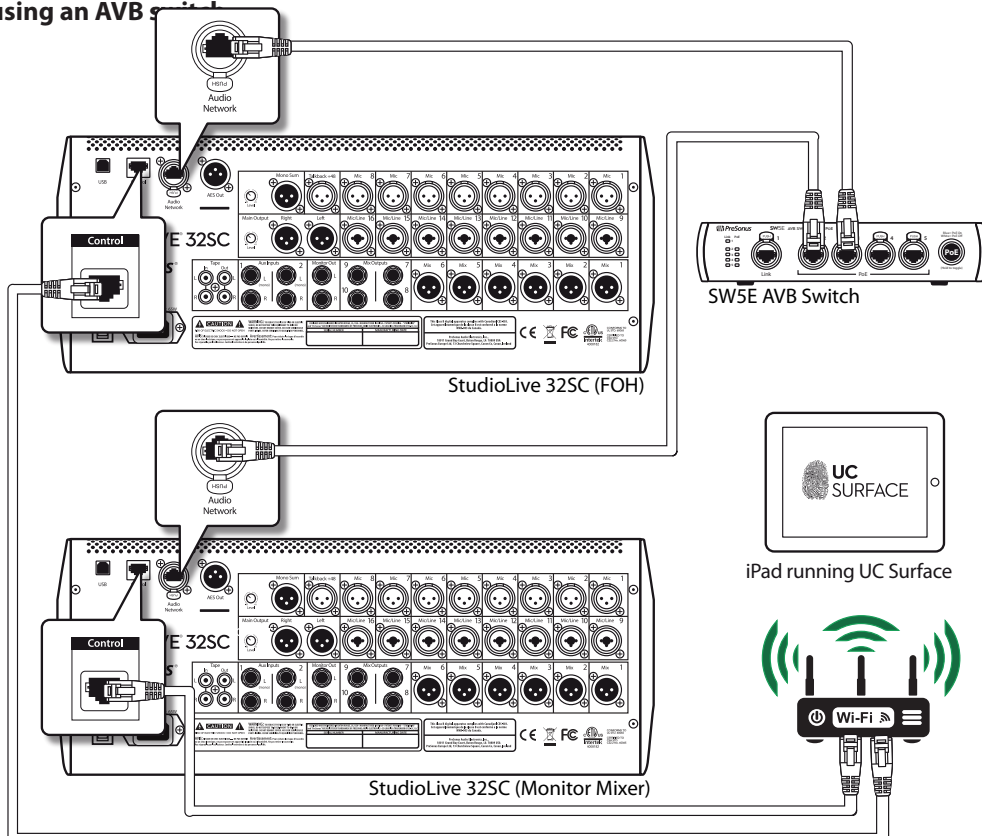

Before continuing verify the following:

- Both mixers are connected via the Audio Network port.
- Both mixers have been updated to the latest firmware.

Step 1: Connect your mixers over AVB

1. Press the Home button on your StudioLive Series III console.

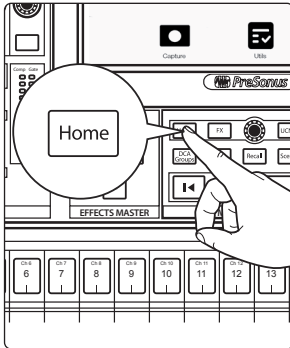

2. Press Audio Routing on the Home Screen.

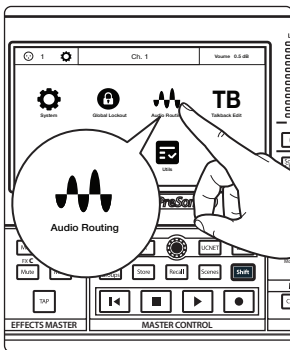

3. Press the Stagebox Setup button on the screen.

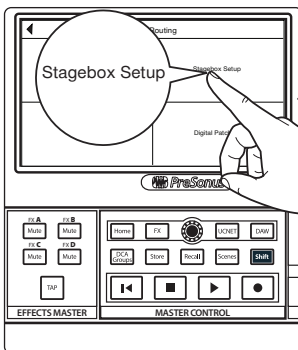

4. Select your StudioLive console mixer at Monitor position from list at the left, then select Monitor Mixer Mode from the Stagebox Setup screen on your FOH StudioLive console mixer.



Step 2: Set Preamp Permissions

Give Preamp Permissions to the FOH StudioLive console. This allows the FOH console to control overall gain, while providing 40 dB (-20 dB to +20 dB) digital gain for the Monitor Mixer Mode console.

From the Stagebox Setup menu, select your Monitor Mixer console and then tap the arrow next to Preamp Permissions menu to select the FOH console mixer.

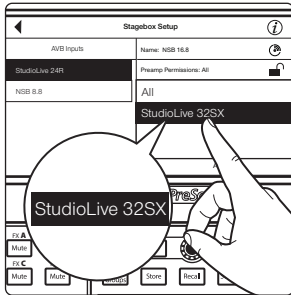

Tap Apply to save the mode and the Preamp Permissions.

Power User Tip: When Apply is pressed, both the selected mixer for preamp permissions and the selected Stagebox Mode are saved simultaneously.

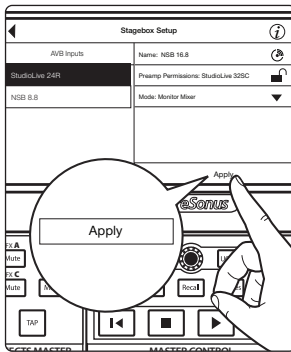

Step 3: Set Network Clock

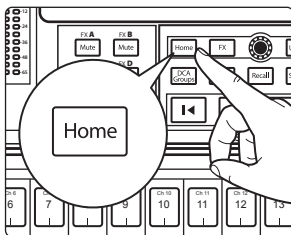

1. Press the Home button on your StudioLive Series III console mixer.

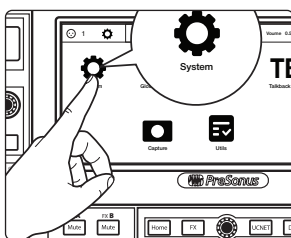

2. Press the System button on your StudioLive Series III mixer touchscreen.

3. The Network clock should be set as follows:

- **FOH Console:** Set The Network Clock to "Internal"
- **Monitor Mixer Console:** Set the Network Clock to "Network Stream"

Step 4: Engage Network Sources

In this configuration, the analog inputs for both mixers can be shared between the two and are patched one-to-one. If you would like to source analog inputs on one mixer for a channel on the other, you must set the channel input source to Network.

1. Press the back arrow twice to return to the Audio Routing screen.

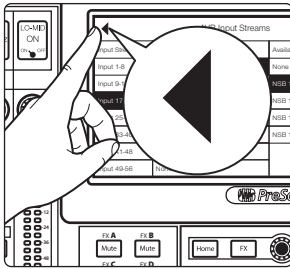

2. Press Digital Patching.

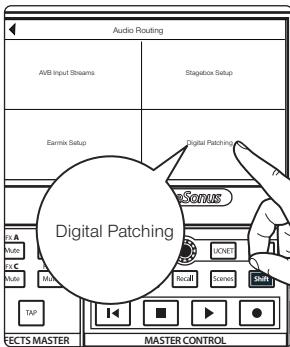

3. Select Input Source and scroll to the desired channels. Assign each to the Network source by pressing the Network button next to each Input.

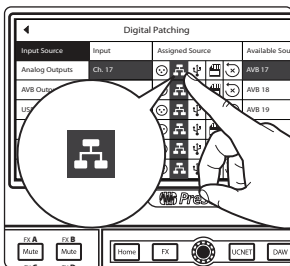

OR

Select each channel and press the Network button from the Input source section in the Fat Channel. To assign multiple Network sources at once, press and hold the Network button until the Select buttons flash, then press the Select button for every channel for which a Network source should be engaged. This will patch the Network source on each channel you select.

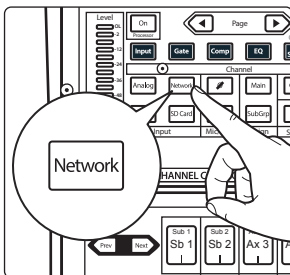

Your StudioLive mixers are now ready to use!

4.4 StudioLive Series III Console Mixer and EarMix 16M

Connect your EarMix 16M to your StudioLive Series III console mixer as pictured below:

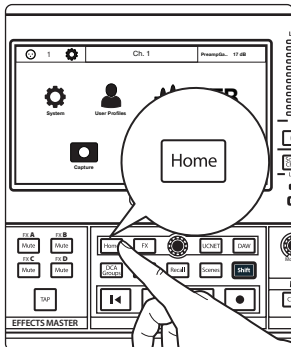
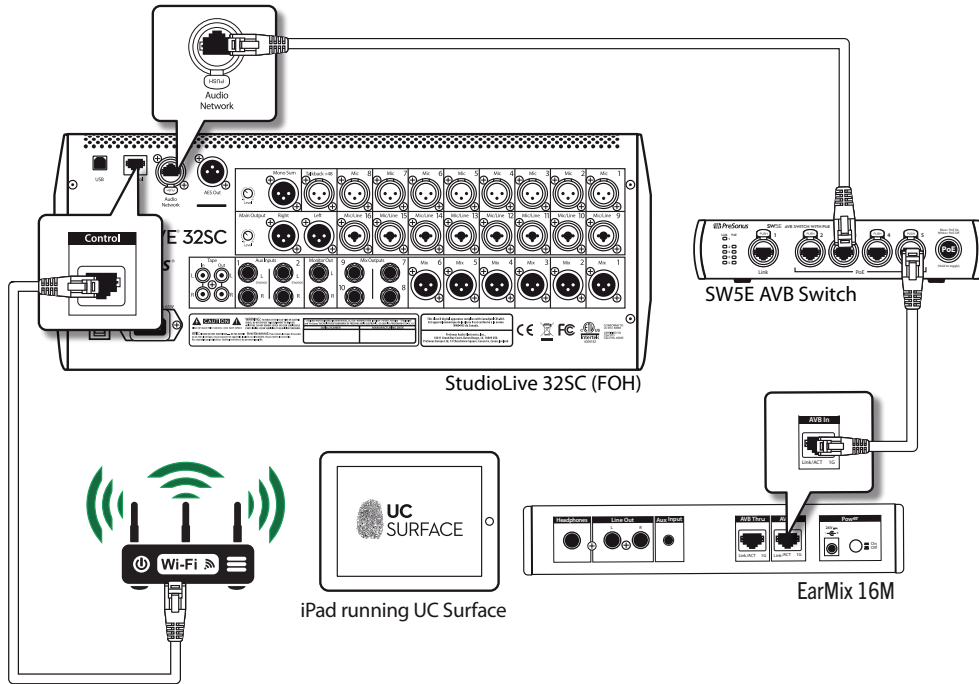

1. Press the Home button on your StudioLive Series III mixer.

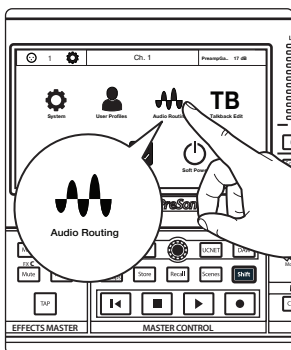

2. Press the Audio Routing icon on the Touchscreen.



3. Press the EarMix Setup button on the Touchscreen.

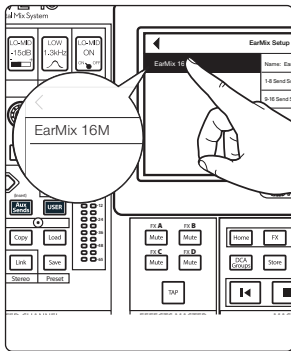

4. Select EarMix 16M from the list on the left.

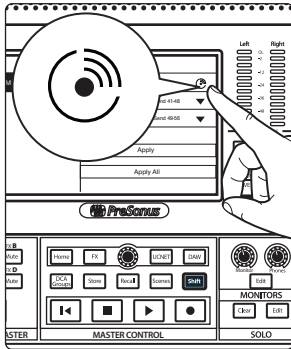

If you are unsure which EarMix 16M is which, press the Identify button. This will flash all the Select buttons on the currently selected EarMix 16M.

Power User Tip: You can rename the Earmixes from this screen by touching the "Earmix16" name to the immediate left of the Identify button.

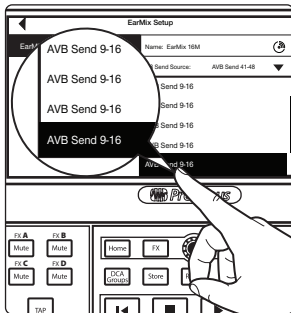

5. Next you will need to select the AVB Sends from your mixer to which you route to your EarMix. By default, AVB Sends 41-56 are patched from Flex Mixes 1-16. In our example, let's patch Sends 41-48 to EarMix Sources 1-8 and Sends 49-56 to EarMix Sources 9-16.

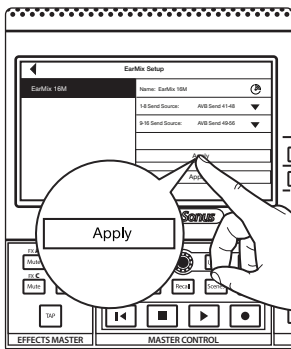

6. Press apply to finish.

Power User Tip: If you are configuring multiple EarMix 16M Personal Monitor Mixers and would like them to receive the same routing from the mixer, press the Apply All button. This will apply the current AVB routings to every EarMix 16M currently on the AVB network.

By default, every Flex Mix on your StudioLive mixer is configured as a pre-fader Aux Mix.

4.5 Putting It All Together: Real World Example

The same stage box can be used as a source for multiple mixers on the network. This situation is common when there is a mixer at Front-of-House and another mixer at Monitor Position. In this example, we will be using an NSB8.8 to add eight additional analog inputs to both a StudioLive 24 console at Front-of-House and a StudioLive 24R configured as a monitor mixer.

Connect your network as shown below and power on your equipment. Because the NSB-series stage boxes have an AVB switch onboard, you can connect two different devices simultaneously to a single NSB stage box. You also have the option of using a stand-alone AVB switch, like the PreSonus SW5e. Either of the configurations below are supported.

All network devices must have a stream from the mixer set to "Internal Clock" on their Mixer Input Stream 1.

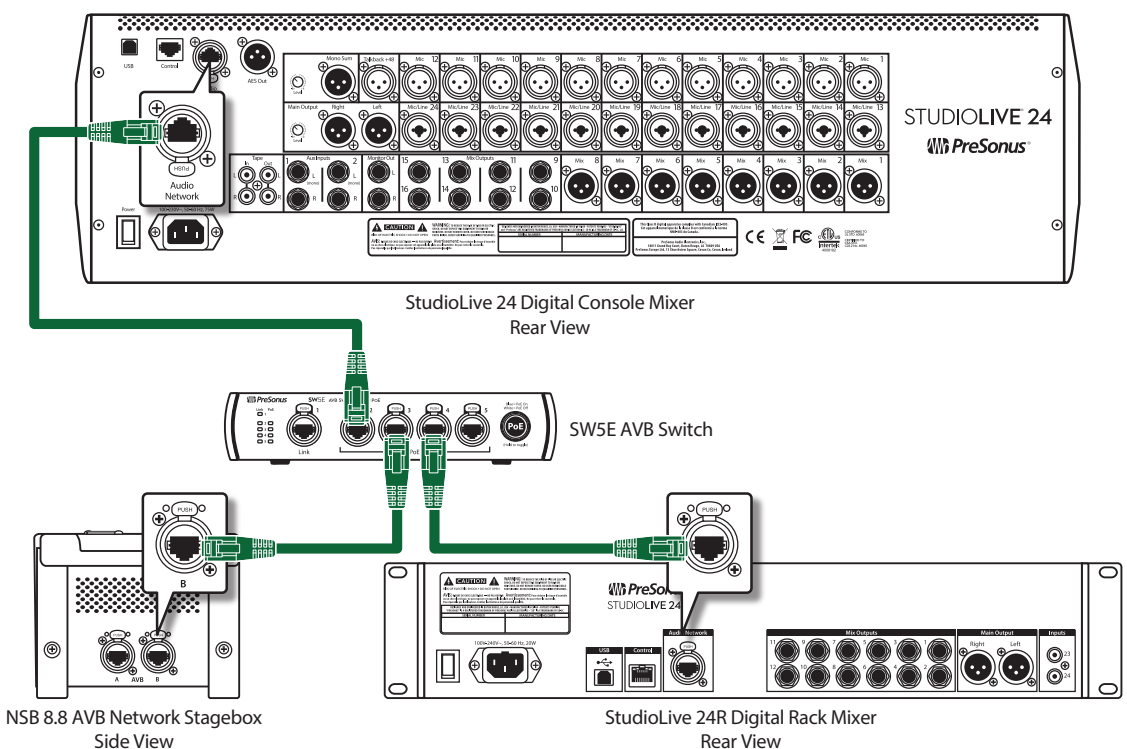
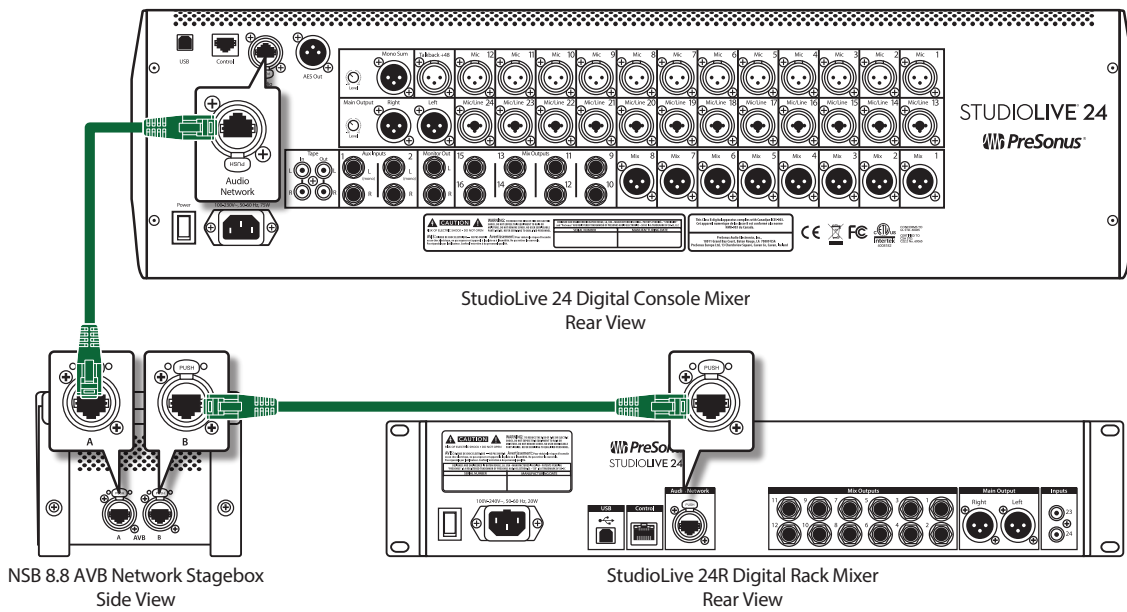

Step 1: Connect Your Rack Mixer (Monitors) to Your Console Mixer (FOH)

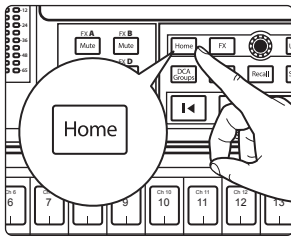

1. Press the Home button on your StudioLive Series III mixer.

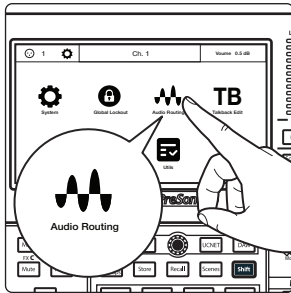

2. Press the Audio Routing icon on the Touchscreen.

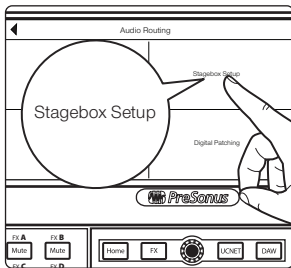

3. Press the Stagebox Setup button on the Touchscreen.

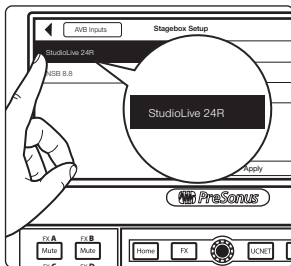

4. Select the StudioLive 24R.

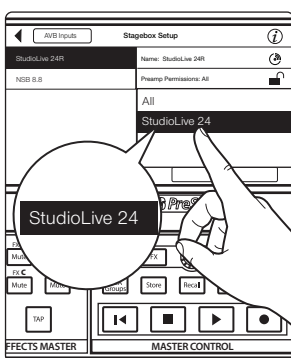

5. In our example, all preamps will be controlled from the Front-of-House mixer, so set the Preamp permissions to StudioLive 24.

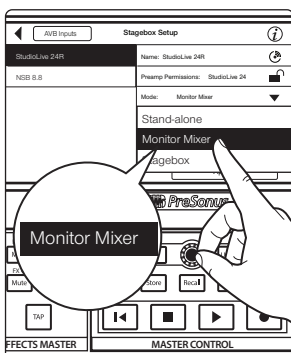

6. Change the Mode to Monitor Mixer.

Note: For complete information on using your rackmount StudioLive Series III mixer as a stage box or monitor mixer with your StudioLive Series III console, please review the StudioLive Series III Stagebox Mode Addendum.

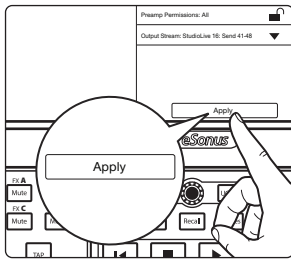

7. Tap Apply.

Step 2: Connect Your Stage Box to Your Console Mixer (FOH)

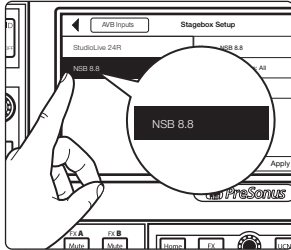

Select the NSB 8.8 from the list on the left.

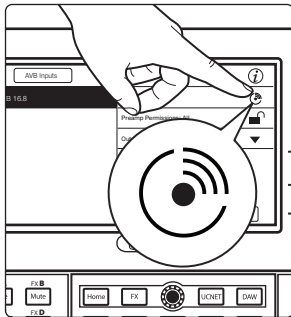

Power User Tip: In applications where you are using multiple NSB-series stage boxes of the same model, you can press the Identify button. This will flash Power / Network LED on the top panel red and green on the currently selected NSB, allowing you to quickly locate your selection.

Step 3: Set Preamp Permissions

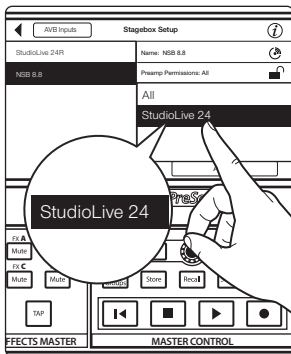

The preamps on NSB-series stage boxes can be controlled from any StudioLive Series III mixer on the network. When you have a stage box feeding more than one mixer, it is recommended that you give only one mixer permission to adjust the NSB preamp levels. In our example, we will be giving permission to the StudioLive 24 at Front-of-House.

Step 4: Patch Outputs

The NSB-series stage box is equipped with 8 outputs to feed floor monitors, mains, or personal monitoring systems. In our example, we will be using these outputs exclusively for floor monitors and since we have a StudioLive 24R dedicated as a monitor mixer, we will be using its AVB Sends to feed the NSB 8.8 outputs.

Note: Because the AVB streams are routed in banks of 8, you can only source these outputs from one mixer on the network.

Send and Return connections over the network to and from the NSB-series stage box must be made from each mixer individually. For console mixers, this routing can be made locally, using the LCD, or remotely from UC Surface. All audio routing for rack mixers must be done remotely using UC Surface.

Note: You must assign an output stream from your mixer that is set to internal clock to your NSB-series stage box so that is clocked properly over the network. If you do not assign an output stream from your mixer, your networked stage box will not be properly synced and you will hear audio artifacts. This is also true when using secondary mixers on the network as well.

Every device needs an output stream connected from the master clock mixer on its input stream 1. When using mixers in Stagebox and Monitor Mixer modes, this is done automatically. Mixers operating in Stand-alone mode will need an output stream routed to them manually. For more information on clocking over AVB, please review the AVB Networking Guide.

In our example, we will be routing the last 8 FlexMixes from the StudioLive 24R to the physical outputs on the NSB 8.8.

1. In Universal Control, connect to the StudioLive 24R.



2. Choose on the Settings Icon.



3. Choose on the Network Tab.

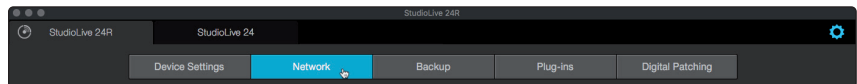

4. In the Stagebox Setup area, select the NSB 8.8.

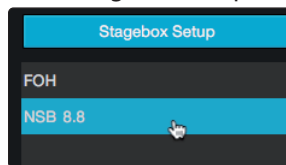

5. From the drop-down menu, select StudioLive 24 Sends 49-56.

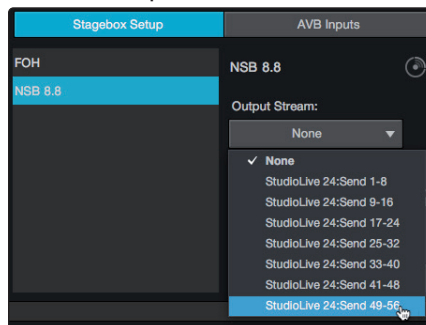

6. Press the Apply button when finished.

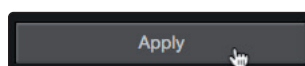

Step 5: Routing inputs to your console mixer

In our example, we are using the NSB 8.8 to add 8 more inputs to the StudioLive 24 create a full 32-channel mixer. We will also be routing the audio from the LCD on the console.

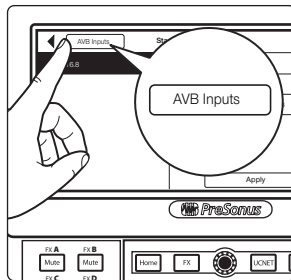

1. On the Stagebox Setup screen, press AVB Inputs.

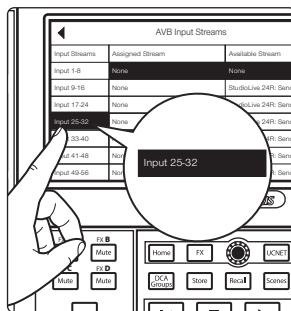

2. Select Input 25-32.

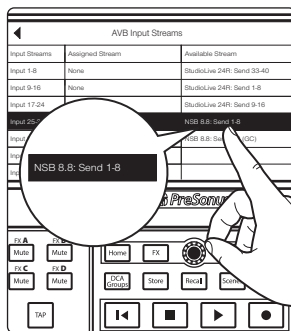

3. From the Available Stream list, use the Value encoder to scroll to NSB 8.8 Send 1-8.

In our example, we will also be using routing inputs 9-24 on the StudioLive 24R as part of our mix on the StudioLive 24. Let's go ahead and route those now.

Your StudioLive 24 is now configured as follows:

- Channels 1-8: No network source available.
- Channels 9-16: Network sourced from StudioLive 24R Inputs 9-16.
- Channels 17-24: Network sourced from StudioLive 24R Inputs 17-24.
- Channels 25-32: Network sourced from NSB8.8 Inputs 1-8.

Step 6: Engaging the Network Sources on your Console Mixer

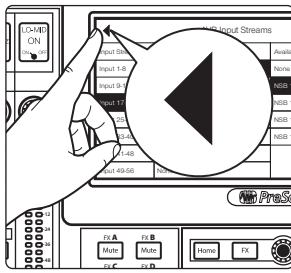

1. Press the back arrow to return to the Audio Routing screen

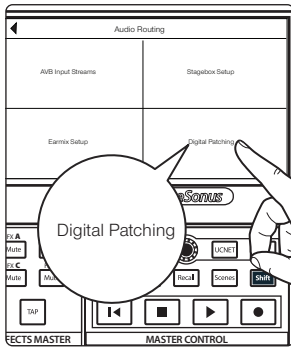

2. Press the Digital Patching button to open the Digital Patching screen.

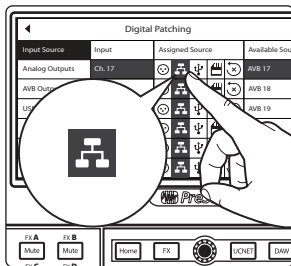

3. Scroll to Inputs 9-32 and assign each to the Network source by pressing the Network button next to each Input.

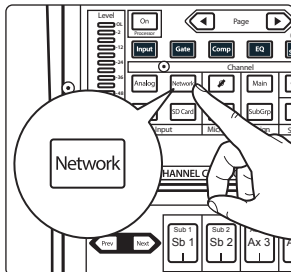

Power User Tip: The Network Source can also be enabled for each channel individually from the Fat Channel. Using the Digital Patching screen allows you to assign the sources to multiple channels at once.

Your NSB 8.8 is now ready to use with your StudioLive 24R. Now let's set it up for the StudioLive 24R!

Step 7: Routing Inputs to your rack mixer

In our example, we are using the NSB 8.8 to also add 8 more inputs to the StudioLive 24R create a full 32-channel mixer. Let's open up UC Surface and get that routed!



1. In UC Surface connected to your StudioLive 24R, press the Settings gear.

2. Click on the Network Tab.

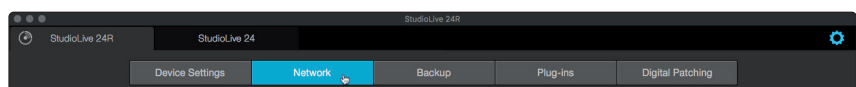

- From the Stagebox Setup area, click on the AVB Inputs tab.

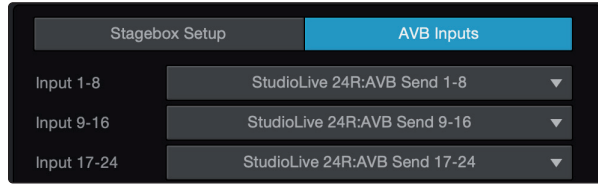

- Choose on the drop-down menu for Input 25-32 and select NSB 8.8: Send 1-8 (GC). These are the gain compensated streams for your NSB 8.8. *Please see the NSB-series Owners Manual for more information.*

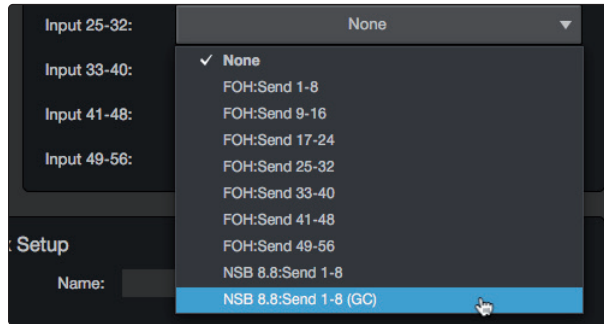

In our example, we will also be using routing inputs 1-8 on the StudioLive 24 as part of our monitor mix. Let's go ahead and route those now.

Your StudioLive 24R is now configured as follows:

- Channels 1-24: Network sourced from StudioLive 24 Inputs 1-24
- Channels 25-32: Network sourced from NSB8.8 Inputs 1-8.

Step 8: Engaging the Network Sources on your Rack Mixer

- Choose on the Digital Patching tab.

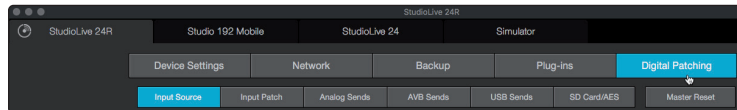

- Choose on the Input Source tab.

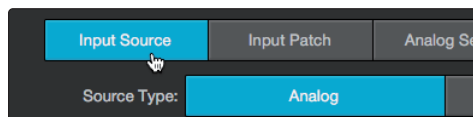

- Choose on the AVB tab.

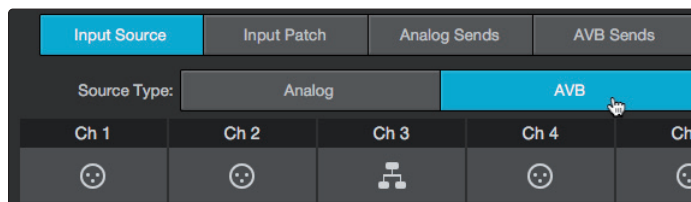

- Choose on the icon on Channels 1-8 and Channels 25-32. This will assign the source for each of these channels to the AVB network.

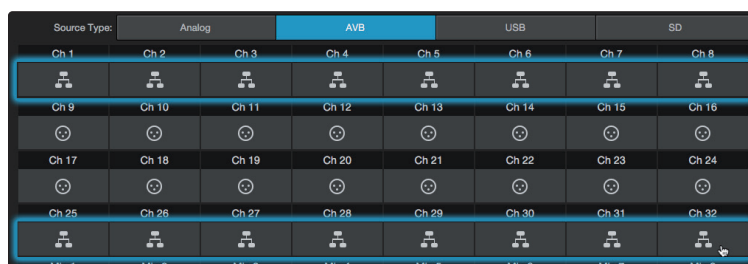

5 Using AVB Streams from Multiple Sources

5.1 AVB Input Stream Routing and Digital Patching

All network devices must have a stream from the mixer set to "Internal Clock" on their Mixer Input Stream 1.

When assigning AVB streams from the AVB Input Streams page (either from the console touch display or in UC Surface), input streams are routed in groups of 8 channels per stream.

The default grouping can be altered using the Digital Patching menu. Digital Patching lets you fine-tune your AVB Sends and change which AVB Send will send which input or output channel on the transmitting mixer.

For example, if you are using AVB Input Streams 1-8 from one mixer to another, you can change the analog source of those 8 streams before they are sent to the receiving mixer.

In the image below, AVB Sends 1-8 (Stream 1) are transmitting channels 1-8 to the receiving console, but using the Available Source list on the right side of the screen, you can choose an AVB Send and change its Assigned Source to be any channel of your choosing:

Digital Patching				Master Reset	i
Input Source	AVB Send	Assigned Source		Available Source	
Analog Sends	AVB 1	Ch. 1	⊗	Ch. 1	
AVB Sends	AVB 2	Ch. 2	⊗	Ch. 2	
USB Sends	AVB 3	Ch. 3	⊗	Ch. 3	
SD Card	AVB 4	Ch. 4	⊗	Ch. 4	
AES	AVB 5	Ch. 5	⊗	Ch. 5	
Reset Sends	AVB 6	Ch. 6	⊗	Ch. 6	

Using the same example above, if you change the Assigned Source for AVB1 to Channel 3 in the Available Source list, and then assign AVB Input Streams 1-8 to Inputs 1-8 on the receiving console, Channel 1 on the receiving console will get its network source from Channel 3 on the transmitting console.

6 Troubleshooting

6.1 System Verification Checklist

Before beginning any advanced troubleshooting, it is recommended that the following checklist be followed:

1. Are all devices updated to the latest version?
 - Universal Control
 - StudioLive Series III console mixers
 - StudioLive Series III rack mixers
 - SW5E (or other) AVB Switch
 - NSB Stage Boxes
 - EarMix 16M (all)
 - QMix-UC on all mobile devices
 - UC Surface on all mobile devices
2. Power cycle the system or the device on which the issue is occurring.
3. The Power Light on all NSB and Earmix16 Devices should be Blue.
4. Verify cable functionality.
 - Yellow AVB Light of all AVB devices are solid and green AVB Light should blink.
 - Audio cabling (XLR, TRS, TS, RCA, etc.)
 - Ethernet cabling (CAT5e, CAT6 or CAT6A). **Note:** *only CAT5e, CAT6 or CAT6A cable has been qualified for use with StudioLive Series III ecosystem products.*
5. Verify AVB Stream assignments.
 - All network devices must have a stream from the mixer set to "Internal Clock" on their Mixer Input Stream 1.
 - Reestablish AVB Input Streams by setting them to "None" and then reassigning the streams to the desired inputs.
6. Verify mixer channel source assignments. Are channels that should be receiving an input source from the Network set to "Network"?
7. Is your Main Bus set to "Analog" input type? **Note:** *With few exceptions, the input source for the Main Bus should always be set to "Analog."*
8. When you press Select for the Main Mix, is "Post Fader" enabled in the Digital Send section?
9. Is your StudioLive rack mixer in the correct mode (Standalone, Stagebox, or Monitor Mixer)?
10. If you have a router connected to your system, is the Control port on your StudioLive Mixer connected to the LAN port on the router and not the "Internet" or "WAN" port?
11. Is the power in the facility stable and clean? If the problem persists, it is recommended that you contact a professional electrician to verify the power.

Added bonus: PreSonus' previously Top Secret recipe for...

Rice Dressing

Ingredients:

- 1 lb ground beef
- 1 lb chopped chicken liver
- 1 onion (diced)
- 2 green peppers (diced)
- 4-6 celery stalks (diced)
- 2 garlic cloves (minced)
- ¼ C. chopped fresh parsley
- 3 C. chicken stock
- 6 C. cooked rice
- 1 Tbs. oil
- Salt and pepper to taste
- Cayenne pepper to taste

Cooking Instructions:

1. In a large pot, heat oil on medium high and add meat, salt, and pepper to taste. Stir until meat begins to brown.
2. Lower heat and add all vegetables. Cook until onions are transparent and celery is very tender. Add stock as necessary to prevent burning.
3. Stir in cooked rice. Add remaining stock and simmer on low until ready to serve.

Advanced AVB Integrator Application Guide

